

PXI Express™

PXIe-1066DC User Manual

August 2017
373547E-01



Worldwide Technical Support and Product Information

ni.com

Worldwide Offices

Visit ni.com/niglobal to access the branch office web sites, which provide up-to-date contact information, support phone numbers, email addresses, and current events.

National Instruments Corporate Headquarters

11500 North Mopac Expressway Austin, Texas 78759-3504 USA Tel: 512 683 0100

For further support information, refer to the [NI Services](#) appendix. To comment on National Instruments documentation, refer to the National Instruments web site at ni.com/info and enter the Info Code [feedback](#).

Legal Information

Limited Warranty

This document is provided 'as is' and is subject to being changed, without notice, in future editions. For the latest version, refer to ni.com/manuals. NI reviews this document carefully for technical accuracy; however, NI MAKES NO EXPRESS OR IMPLIED WARRANTIES AS TO THE ACCURACY OF THE INFORMATION CONTAINED HEREIN AND SHALL NOT BE LIABLE FOR ANY ERRORS.

NI warrants that its hardware products will be free of defects in materials and workmanship that cause the product to fail to substantially conform to the applicable NI published specifications for one (1) year from the date of invoice.

For a period of ninety (90) days from the date of invoice, NI warrants that (i) its software products will perform substantially in accordance with the applicable documentation provided with the software and (ii) the software media will be free from defects in materials and workmanship.

If NI receives notice of a defect or non-conformance during the applicable warranty period, NI will, in its discretion: (i) repair or replace the affected product, or (ii) refund the fees paid for the affected product. Repaired or replaced Hardware will be warranted for the remainder of the original warranty period or ninety (90) days, whichever is longer. If NI elects to repair or replace the product, NI may use new or refurbished parts or products that are equivalent to new in performance and reliability and are at least functionally equivalent to the original part or product.

You must obtain an RMA number from NI before returning any product to NI. NI reserves the right to charge a fee for examining and testing Hardware not covered by the Limited Warranty.

This Limited Warranty does not apply if the defect of the product resulted from improper or inadequate maintenance, installation, repair, or calibration (performed by a party other than NI); unauthorized modification; improper environment; use of an improper hardware or software key; improper use or operation outside of the specification for the product; improper voltages; accident, abuse, or neglect; or a hazard such as lightning, flood, or other act of nature.

THE REMEDIES SET FORTH ABOVE ARE EXCLUSIVE AND THE CUSTOMER'S SOLE REMEDIES, AND SHALL APPLY EVEN IF SUCH REMEDIES FAIL OF THEIR ESSENTIAL PURPOSE.

EXCEPT AS EXPRESSLY SET FORTH HEREIN, PRODUCTS ARE PROVIDED "AS IS" WITHOUT WARRANTY OF ANY KIND AND NI DISCLAIMS ALL WARRANTIES, EXPRESSED OR IMPLIED, WITH RESPECT TO THE PRODUCTS, INCLUDING ANY IMPLIED WARRANTIES OF MERCHANTABILITY, FITNESS FOR A PARTICULAR PURPOSE, TITLE OR NON-INFRINGEMENT, AND ANY WARRANTIES THAT MAY ARISE FROM USAGE OF TRADE OR COURSE OF DEALING. NI DOES NOT WARRANT, GUARANTEE, OR MAKE ANY REPRESENTATIONS REGARDING THE USE OF OR THE RESULTS OF THE USE OF THE PRODUCTS IN TERMS OF CORRECTNESS, ACCURACY, RELIABILITY, OR OTHERWISE. NI DOES NOT WARRANT THAT THE OPERATION OF THE PRODUCTS WILL BE UNINTERRUPTED OR ERROR FREE.

In the event that you and NI have a separate signed written agreement with warranty terms covering the products, then the warranty terms in the separate agreement shall control.

Copyright

Under the copyright laws, this publication may not be reproduced or transmitted in any form, electronic or mechanical, including photocopying, recording, storing in an information retrieval system, or translating, in whole or in part, without the prior written consent of National Instruments Corporation.

National Instruments respects the intellectual property of others, and we ask our users to do the same. NI software is protected by copyright and other intellectual property laws. Where NI software may be used to reproduce software or other materials belonging to others, you may use NI software only to reproduce materials that you may reproduce in accordance with the terms of any applicable license or other legal restriction.

End-User License Agreements and Third-Party Legal Notices

You can find end-user license agreements (EULAs) and third-party legal notices in the following locations:

- Notices are located in the <National Instruments>_Legal Information and <National Instruments> directories.
- EULAs are located in the <National Instruments>\Shared\MDF\Legal\license directory.
- Review <National Instruments>_Legal Information.txt for information on including legal information in installers built with NI products.

U.S. Government Restricted Rights

If you are an agency, department, or other entity of the United States Government ("Government"), the use, duplication, reproduction, release, modification, disclosure or transfer of the technical data included in this manual is governed by the Restricted Rights provisions under Federal Acquisition Regulation 52.227-14 for civilian agencies and Defense Federal Acquisition Regulation Supplement Section 252.227-7014 and 252.227-7015 for military agencies.

Trademarks

Refer to the *NI Trademarks and Logo Guidelines* at ni.com/trademarks for more information on National Instruments trademarks.

ARM, Keil, and μ Vision are trademarks or registered of ARM Ltd or its subsidiaries.

LEGO, the LEGO logo, WEDO, and MINDSTORMS are trademarks of the LEGO Group.

TETRIX by Pitsco is a trademark of Pitsco, Inc.

FIELDBUS FOUNDATION™ and FOUNDATION™ are trademarks of the Fieldbus Foundation.

EtherCAT® is a registered trademark of and licensed by Beckhoff Automation GmbH.

CANopen® is a registered Community Trademark of CAN in Automation e.V.

DeviceNet™ and EtherNet/IP™ are trademarks of ODVA.

Go!, SensorDAQ, and Vernier are registered trademarks of Vernier Software & Technology. Vernier Software & Technology and vernier.com are trademarks or trade dress.

Xilinx is the registered trademark of Xilinx, Inc.

Taprite and Trilobular are registered trademarks of Research Engineering & Manufacturing Inc.

FireWire® is the registered trademark of Apple Inc.

Linux® is the registered trademark of Linus Torvalds in the U.S. and other countries.

Handle Graphics®, MATLAB®, Real-Time Workshop®, Simulink®, Stateflow®, and xPC TargetBox® are registered trademarks, and TargetBox™ and Target Language Compiler™ are trademarks of The MathWorks, Inc.

Tektronix®, Tek, and Tektronix, Enabling Technology are registered trademarks of Tektronix, Inc.

The Bluetooth® word mark is a registered trademark owned by the Bluetooth SIG, Inc.

The ExpressCard™ word mark and logos are owned by PCMCIA and any use of such marks by National Instruments is under license.

The mark LabWindows is used under a license from Microsoft Corporation. Windows is a registered trademark of Microsoft Corporation in the United States and other countries.

Other product and company names mentioned herein are trademarks or trade names of their respective companies.

Members of the National Instruments Alliance Partner Program are business entities independent from National Instruments and have no agency, partnership, or joint-venture relationship with National Instruments.

Patents

For patents covering National Instruments products/technology, refer to the appropriate location: **Help»Patents** in your software, the `patents.txt` file on your media, or the *National Instruments Patent Notice* at ni.com/patents.

Export Compliance Information

Refer to the *Export Compliance Information* at ni.com/legal/export-compliance for the National Instruments global trade compliance policy and how to obtain relevant HTS codes, ECCNs, and other import/export data.

WARNING REGARDING USE OF NATIONAL INSTRUMENTS PRODUCTS

YOU ARE ULTIMATELY RESPONSIBLE FOR VERIFYING AND VALIDATING THE SUITABILITY AND RELIABILITY OF THE PRODUCTS WHENEVER THE PRODUCTS ARE INCORPORATED IN YOUR SYSTEM OR APPLICATION, INCLUDING THE APPROPRIATE DESIGN, PROCESS, AND SAFETY LEVEL OF SUCH SYSTEM OR APPLICATION.

PRODUCTS ARE NOT DESIGNED, MANUFACTURED, OR TESTED FOR USE IN LIFE OR SAFETY CRITICAL SYSTEMS, HAZARDOUS ENVIRONMENTS OR ANY OTHER ENVIRONMENTS REQUIRING FAIL-SAFE PERFORMANCE, INCLUDING IN THE OPERATION OF NUCLEAR FACILITIES; AIRCRAFT NAVIGATION; AIR TRAFFIC CONTROL SYSTEMS; LIFE SAVING OR LIFE SUSTAINING SYSTEMS OR SUCH OTHER MEDICAL DEVICES; OR ANY OTHER APPLICATION IN WHICH THE FAILURE OF THE PRODUCT OR SERVICE COULD LEAD TO DEATH, PERSONAL INJURY, SEVERE PROPERTY DAMAGE OR ENVIRONMENTAL HARM (COLLECTIVELY, "HIGH-RISK USES"). FURTHER, PRUDENT STEPS MUST BE TAKEN TO PROTECT AGAINST FAILURES, INCLUDING PROVIDING BACK-UP AND SHUT-DOWN MECHANISMS. NI EXPRESSLY DISCLAIMS ANY EXPRESS OR IMPLIED WARRANTY OF FITNESS OF THE PRODUCTS OR SERVICES FOR HIGH-RISK USES.

Compliance

Electromagnetic Compatibility Information

This hardware has been tested and found to comply with the applicable regulatory requirements and limits for electromagnetic compatibility (EMC) as indicated in the hardware's Declaration of Conformity (DoC)¹. These requirements and limits are designed to provide reasonable protection against harmful interference when the hardware is operated in the intended electromagnetic environment. In special cases, for example when either highly sensitive or noisy hardware is being used in close proximity, additional mitigation measures may have to be employed to minimize the potential for electromagnetic interference.

While this hardware is compliant with the applicable regulatory EMC requirements, there is no guarantee that interference will not occur in a particular installation. To minimize the potential for the hardware to cause interference to radio and television reception or to experience unacceptable performance degradation, install and use this hardware in strict accordance with the instructions in the hardware documentation and the DoC¹.

If this hardware does cause interference with licensed radio communications services or other nearby electronics, which can be determined by turning the hardware off and on, you are encouraged to try to correct the interference by one or more of the following measures:

- Reorient the antenna of the receiver (the device suffering interference).
- Relocate the transmitter (the device generating interference) with respect to the receiver.
- Plug the transmitter into a different outlet so that the transmitter and the receiver are on different branch circuits.

Some hardware may require the use of a metal, shielded enclosure (windowless version) to meet the EMC requirements for special EMC environments such as, for marine use or in heavy industrial areas. Refer to the hardware's user documentation and the DoC¹ for product installation requirements.

When the hardware is connected to a test object or to test leads, the system may become more sensitive to disturbances or may cause interference in the local electromagnetic environment.

Operation of this hardware in a residential area is likely to cause harmful interference. Users are required to correct the interference at their own expense or cease operation of the hardware.

Changes or modifications not expressly approved by National Instruments could void the user's right to operate the hardware under the local regulatory rules.

¹ The Declaration of Conformity (DoC) contains important EMC compliance information and instructions for the user or installer. To obtain the DoC for this product, visit ni.com/certification, search by model number or product line, and click the appropriate link in the Certification column.

Contents

About This Manual

Related Documentation	ix
-----------------------------	----

Chapter 1

Getting Started

Unpacking.....	1-1
What You Need to Get Started	1-1
Key Features	1-2
Chassis Description	1-3
Optional Equipment.....	1-4
EMC Filler Panels	1-4
Rack Mount Kit	1-4
Slot Blockers.....	1-4
PXIe-1066DC Chassis Backplane Overview	1-5
Interoperability with CompactPCI.....	1-5
System Controller Slot.....	1-5
Hybrid Peripheral Slots	1-6
PXI Peripheral Slots	1-6
PXI Express Peripheral Slots.....	1-6
System Timing Slot	1-6
PXI Local Bus	1-8
PXI Trigger Bus.....	1-9
System Reference Clock.....	1-9
PXIe_SYNC_CTRL.....	1-12

Chapter 2

Installation and Configuration

Safety Information.....	2-1
Chassis Cooling Considerations	2-2
Providing Adequate Clearance	2-2
Chassis Ambient Temperature Definition	2-4
Setting Fan Speed	2-5
Installing Filler Panels	2-5
Installing Slot Blockers	2-5
Fan Access Door Clearance.....	2-5
Rack Mounting	2-6
Connecting to Safety Ground and Power Source	2-6
Power-On Test.....	2-7
Installing a PXI Express System Controller	2-8
Installing Peripheral Modules.....	2-9
Remote System Monitoring.....	2-11
Default Configuration Settings.....	2-12

Contents

Chassis LED Indicators 2-12
Remote Inhibit and Fault Monitoring 2-14
Inhibit Mode Switch 2-15
PXI_CLK10 Connectors 2-15
PXI Express System Configuration with MAX 2-15
 PXI-1 System Configuration 2-16
 Trigger Configuration in MAX 2-17
 PXI Trigger Bus Routing 2-17
Using System Configuration and Initialization Files 2-18

**Chapter 3
Maintenance**

Service Interval 3-1
Preparation 3-1
Cleaning 3-1
 Interior Cleaning 3-1
 Exterior Cleaning 3-2
Replacing a Modular Power Supply 3-2
 Removal 3-2
 Installation 3-5
Replacing a Modular Fan Assembly 3-6
 Removal 3-6
 Installation 3-8

**Appendix A
Specifications**

**Appendix B
Pinouts**

**Appendix C
NI Services**

Glossary

Index

About This Manual

The *PXIe-1066DC User Manual* describes the features of the PXIe-1066DC chassis and contains information about configuring the chassis, installing the modules, and operating the chassis.

Related Documentation

The following documents contain information that you might find helpful as you read this manual:

- IEEE 1101.1-1991, *IEEE Standard for Mechanical Core Specifications for Microcomputers Using IEC 603-2 Connectors*
- IEEE 1101.10, *IEEE Standard for Additional Mechanical Specifications for Microcomputers Using IEEE 1101.1 Equipment Practice*
- *PICMG EXP.0 R1.0 CompactPCI Express Specification*, PCI Industrial Computers Manufacturers Group
- *PCI Express Base Specification*, Revision 1.1, PCI Special Interest Group
- *PXI-5 PXI Express Hardware Specification*, Revision 2.0, PXI Systems Alliance

Getting Started

This chapter describes the key features of the PXIe-1066DC chassis and lists the kit contents and optional equipment you can order from National Instruments.

Unpacking

Carefully inspect the shipping container and the chassis for damage. Check for visible damage to the metal work. Check to make sure all handles, hardware, and switches are undamaged. Inspect the inner chassis for any possible damage, debris, or detached components. If damage appears to have been caused during shipment, file a claim with the carrier. Retain the packing material for possible inspection and/or reshipment.

What You Need to Get Started

The PXIe-1066DC chassis kit contains the following items:

- PXIe-1066DC chassis
- Filler panels
- Power cable
- PXIe-1066DC User Manual*
- Software media with *PXI Platform Services 2.0* or higher
- Read Me First: Safety and Electromagnetic Compatibility*
- Chassis number labels
- Inhibit fault cable connector
- Ferrite bead for use with redundant power supplies

Key Features

The PXIe-1066DC chassis combines a high-performance 18-slot PXI Express backplane with a high-output power supply and a structural design that has been optimized for maximum usability in a wide range of applications. The chassis' modular design ensures a high level of maintainability, resulting in a very low mean time to repair (MTTR). The chassis also features redundant power supplies and fans designed to maximize system availability. The PXIe-1066DC chassis fully complies with the *PXI-5 PXI Express Hardware Specification*, offering advanced timing and synchronization features.

The key features of the PXIe-1066DC chassis include the following:

High Performance for Instrumentation Requirements

- Up to 1 GB/s (single direction) per PXI Express slot dedicated bandwidth (x4 PCIe)
- 38 W per slot cooling meets increased PXI Express cooling requirements
- Low-jitter internal 10 MHz reference clock for PXI slots with ± 25 ppm stability
- Low-jitter internal 100 MHz reference clock for PXI Express slots with ± 25 ppm stability
- Quiet operation for 0 to 30 °C at 49.8 dBA
- Variable speed fan controller optimizes cooling and acoustic emissions
- Remote power-inhibit control
- Complies with PXI and CompactPCI Specifications

High Reliability

- 0 to 50 °C operating temperature range
- Power supply, temperature, and fan monitoring
- HALT tested for increased reliability
- Ethernet interface for remote monitoring

High Availability

- Dual redundant, hot-swappable power supplies
- Redundant, hot-swappable chassis fans

Multi-Chassis Support

- PXI Express System Timing Slot for tight synchronization across chassis
- Front CLK10 I/O connectors
- Switchless CLK10 routing

Optional Features

- Front and rear rack-mount kits
- Replacement power supply
- EMC filler panels
- Slot blockers for improved cooling performance
- Factory installation services

Chassis Description

Figures 1-1 and 1-2 show the key features of the PXIe-1066DC chassis front and back panels. Figure 1-1 shows the front view of the PXIe-1066DC. Figure 1-2 shows the rear view of the PXIe-1066DC.

Figure 1-1. Front View of the PXIe-1066DC Chassis (with Optional Filler Panels)

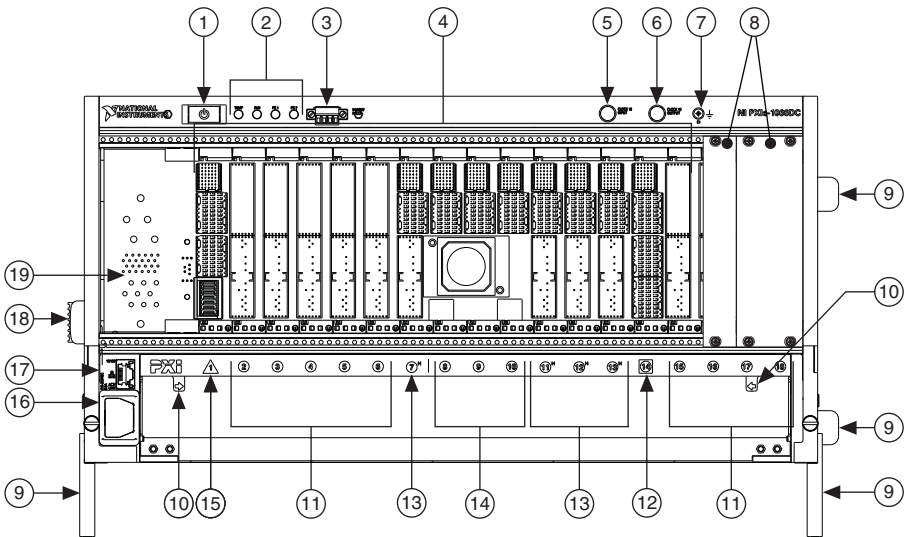

1 Power Inhibit Switch	9 Removable Feet	15 PXI Express System Controller Slot
2 LEDs	10 Fan Door Latch	16 Power Connector
3 Inhibit/Fault Connector	11 PXI Peripheral Slots (9x)	17 Ethernet Port
4 Backplane Connectors	12 PXI Express System Timing Slot	18 Chassis Carry Handle
5 Clk10 Input	13 PXI Express Hybrid Peripheral Slots (4x)	19 System Controller Expansion Slots
6 Clk10 Output	14 PXI Express Peripheral Slots (3x)	
7 Ground Terminal		
8 PXI Filler Panels (Optional)		

Figure 1-2. Rear View of the PXIe-1066DC Chassis

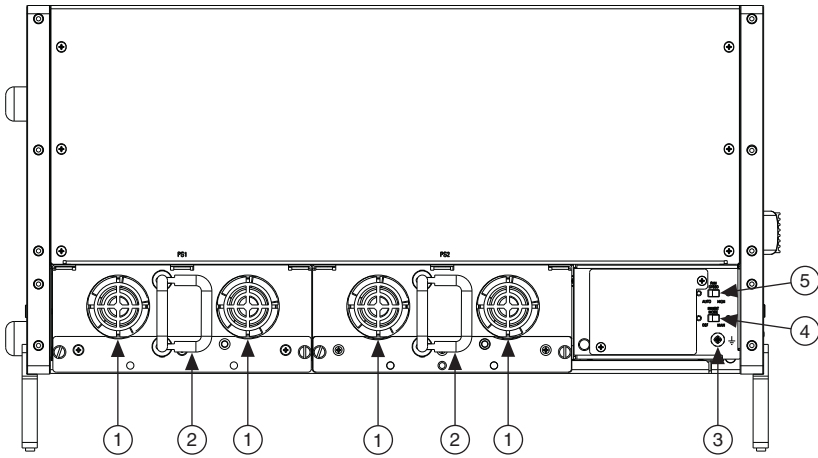

- | | | |
|----------------------------|--------------------------------|-----------------------------|
| 1 Power Supply Cooling Fan | 3 Earth Ground Terminal | 5 Fan Speed Selector Switch |
| 2 Power Supply Handle | 4 Inhibit Mode Selector Switch | |

Optional Equipment

Contact National Instruments to order the following options for the PXIe-1066DC chassis.

EMC Filler Panels

Optional EMC filler panel kits are available from National Instruments.

Rack Mount Kit

There are two optional kits for mounting the PXIe-1066DC chassis into a rack. The first option is a pair of mounting brackets for use on the front of the chassis. The second option is a rear rack mount kit. The rear rack mount kit differs from the front kit to allow for easier installation into the rack. For more information, refer to Figure A-3, [NI Chassis Rack Mount Kit Components](#).

Slot Blockers

Optional slot blocker kits are available from National Instruments for improved thermal performance when all slots are not used.

PXIe-1066DC Chassis Backplane Overview

This section provides an overview of the backplane features for the PXIe-1066DC chassis.

Interoperability with CompactPCI

The design of the PXIe-1066DC provides you the flexibility to use the following devices in a single PXI Express chassis:

- PXI Express compatible products
- CompactPCI Express compatible 4-Link system controller products
- CompactPCI Express compatible Type-2 peripheral products
- PXI peripheral products
- Standard CompactPCI peripheral products

System Controller Slot

The system controller slot is Slot 1 of the chassis and is a 4-Link configuration system slot as defined by the CompactPCI Express and PXI Express specifications. It has three system controller expansion slots for system controller modules that are wider than one slot. These slots allow the system controller to expand to the left to prevent the system controller from using peripheral slots.

The backplane routes a x4 PCI Express link from the system controller slot to slots 7 and 8, and a x1 PCI Express link to a PCI Express to PCI Translation Bridge on the backplane. The PCI Express to PCI Translation Bridge on the backplane provides a 32-bit/33MHz PCI bus to slots 2 to 7.

The second PCI Translation Bridge provides PCI bus to slots 11, 12, 13, 15, 16, 17, and 18 (not to slot 14).

A x4 link goes to the PXI Express switch and the PCI Express connectivity of slots 9 to 14 is connected through the switch.

The system controller slot also has connectivity to some PXI features such as: PXI_CLK10, PXI Star, PXI Trigger Bus and PXI Local Bus 6.

By default, the system controller will control the power supply with the PS_ON# signal. A logic low on this line will turn the power supply on.



Note The Inhibit Mode switch on the rear of the chassis must be in the **Default** position for the system controller to have control of the power supply. Refer to the [Inhibit Mode Switch](#) section of Chapter 2, *Installation and Configuration*, for details about the Inhibit Mode switch.

Hybrid Peripheral Slots

The chassis provides four hybrid peripheral slots as defined by the *PXI-5 PXI Express Hardware Specification*: slot 7 and slots 11 to 13. A hybrid peripheral slot can accept the following peripheral modules:

- A PXI Express Peripheral with x4 or x1 PCI Express link to the system slot or through a switch to the system slot.
- A CompactPCI Express Type-2 Peripheral with x4 or x1 PCI Express link to the system slot or through a switch to the system slot.
- A hybrid-compatible PXI Peripheral module that has been modified by replacing the J2 connector with an XJ4 connector installed in the upper eight rows of J2. Refer to the *PXI Express Specification* for details. The PXI Peripheral communicates through the backplane's 32-bit PCI bus.
- A CompactPCI 32-bit peripheral on the backplane's 32-bit PCI bus.

The hybrid peripheral slots provide full PXI Express functionality and 32-bit PXI functionality except for PXI Local Bus. The hybrid peripheral slot only connects to PXI Local Bus 6 left and right.

PXI Peripheral Slots

There are nine PXI peripheral slots which will accept PXI or CompactPCI peripherals: slots 2 to 6 and slots 15 to 18. These slots are on the backplane's 32-bit PCI busses. These slots offer full PXI functionality, but have no PXI Express features. The 64-bit PCI signals on the P2 connectors are not connected.

PXI Express Peripheral Slots

There are three PXI Express peripheral slots: slots 8 to 10. Slot 8 is directly connected to the system slot with a x4 PCI Express link. Slots 9 and 10 are connected to the system slot through a PCI Express switch. PXI Express peripheral slots can accept the following modules:

- A PXI Express Peripheral with x4 or x1 PCI Express link to the system slot or through a switch to the system slot.
- A CompactPCI Express Type-2 Peripheral with x4 or x1 PCI Express link to the system slot or through a switch to the system slot.

System Timing Slot

The System Timing Slot is slot 14. The system timing slot will accept the following peripheral modules:

- A PXI Express System Timing Module with x4 or x1 PCI Express link to the system slot through a PCIe switch.
- A PXI Express Peripheral with x4 or x1 PCI Express link to the system slot through a PCIe switch.
- A CompactPCI Express Type-2 Peripheral with x4 or x1 PCI Express link to the system slot through a PCIe switch.

The system timing slot has 3 dedicated differential pairs (PXIe_DSTAR) connected from the TP1 and TP2 connectors to the XP3 connector for each PXI Express peripheral or hybrid peripheral slot, as well as routed back to the XP3 connector of the system timing slot as shown in Figure 1-3. The PXIe_DSTAR pairs can be used for high-speed triggering, synchronization and clocking. Refer to the *PXI Express Specification* for details.

The system timing slot also has a single-ended (PXI Star) trigger connected to every slot. Refer to Figure 1-3 for details.

The system timing slot has a pin (PXI_CLK10_IN) through which a system timing module may source a 10MHz clock to which the backplane will phase-lock. Refer to the [System Reference Clock](#) section for details.

The system timing slot has a pin (PXIe_SYNC_CTRL) through which a system timing module can control the PXIe_SYNC100 timing. Refer to the *PXI Express Specification* and the [PXIe_SYNC_CTRL](#) section of this chapter for details.

Figure 1-3. PXIe_DSTAR and PXI Star Connectivity Diagram

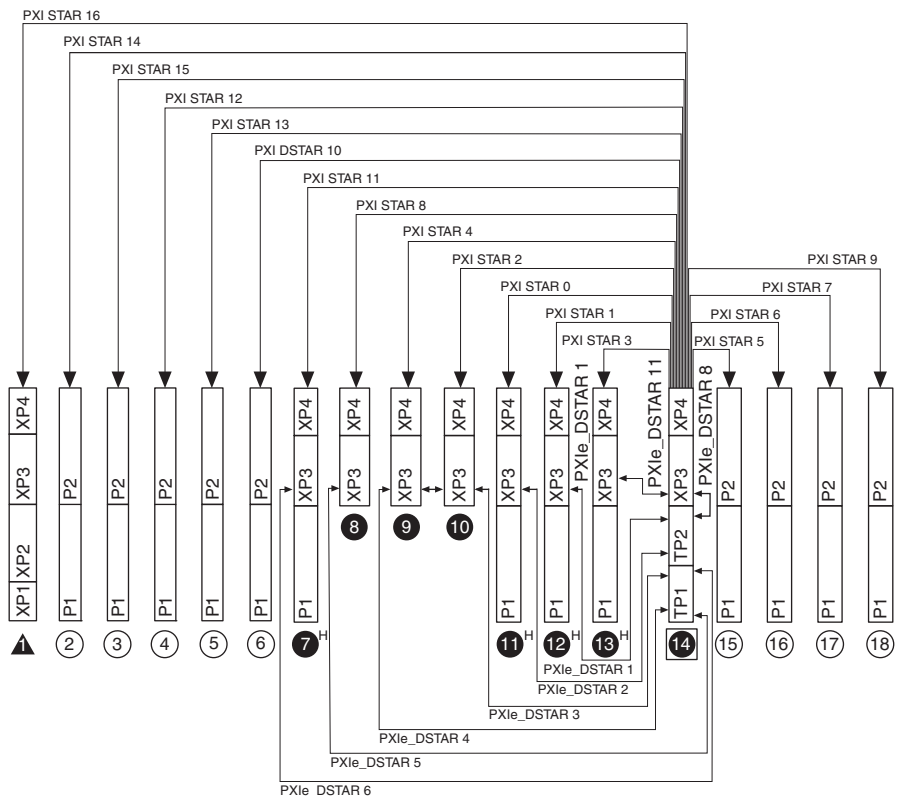

PXI Local Bus

The PXI backplane local bus is a daisy-chained bus that connects each peripheral slot with adjacent peripheral slots to the left and right, as shown in Figure 1-4.

The backplane routes the full 13-line PXI Local Bus between adjacent PXI slots (slots 2 to 6 and 15 to 18) and PXI Local Bus 6 between all other slots. Refer to Figure 1-4 for details. The left local bus 6 from slot 1 is not routed anywhere and the right local bus signals from slot 18 are not routed anywhere.

Local bus signals may range from high-speed TTL signals to analog signals as high as 42 V.

Initialization software uses the configuration information specific to each adjacent peripheral module to evaluate local bus compatibility.

Figure 1-4. PXI Trigger Bus and Local Bus Connectivity Diagram

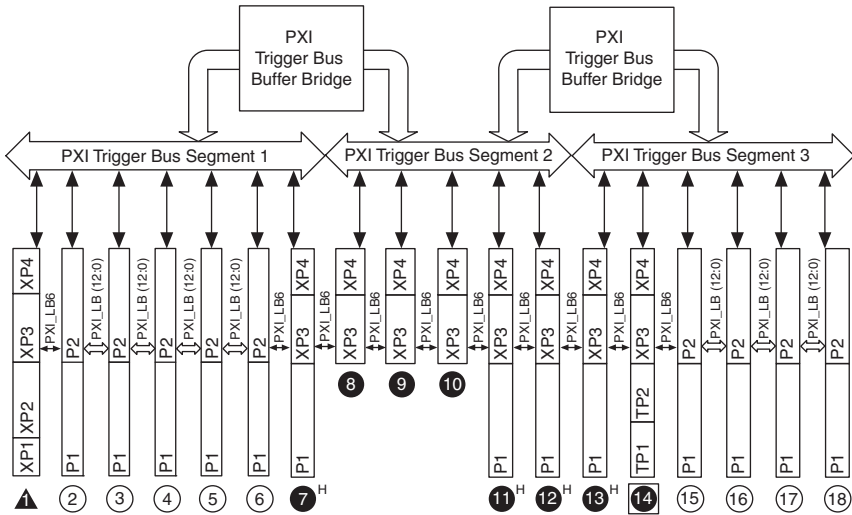

PXI Trigger Bus

All slots on the same PXI bus segment share eight PXI trigger lines. You can use these trigger lines in a variety of ways. For example, you can use triggers to synchronize the operation of several different PXI peripheral modules. In other applications, one module located in the system timing slot can control carefully timed sequences of operations performed on other modules in the system. Modules can pass triggers to one another, allowing precisely timed responses to asynchronous external events the system is monitoring or controlling.

The PXI trigger lines from adjacent PXI trigger bus segments can be routed in either direction across the PXI trigger bridges through buffers. This allows you to send trigger signals to, and receive trigger signals from, every slot in the chassis. Static trigger routing (user-specified line and directional assignments) can be configured through Measurement & Automation Explorer (MAX). Dynamic routing of triggers (automatic line assignments) is supported through certain National Instruments drivers like NI-DAQmx.



Note Although any trigger line may be routed in either direction, it cannot be routed in more than one direction at a time.

System Reference Clock

The PXIe-1066DC chassis supplies the PXI 10 MHz system clock signal (PXI_CLK10) independently driven to each peripheral slot and PXIe_CLK100 and PXIe_SYNC100 to the PXI Express slots, hybrid slots, and system timing slot.

An independent buffer (having a source impedance matched to the backplane and a skew of less than 1 ns between slots) drives PXI_CLK10 to each peripheral slot. Refer to Figure 1-5 for the routing configuration of PXI_CLK10. You can use this common reference clock signal to synchronize multiple modules in a measurement or control system.

An independent buffer drives PXIe_CLK100 to the PXI Express peripheral slots, hybrid peripheral slots, and system timing slot. Refer to Figure 1-5 for the routing configuration of PXIe_CLK100. These clocks are matched in skew to less than 100 ps. The differential pair must be terminated on the peripheral with LVPECL termination for the buffer to drive PXIe_CLK100 so that when there is no peripheral or a peripheral that does not connect to PXIe_CLK100, there is no clock being driven on the pair to that slot.

An independent buffer drives PXIe_SYNC100 to the PXI Express peripheral slots, hybrid peripheral slots, and system timing slot. Refer to Figure 1-5 for the routing configuration of PXIe_SYNC100. The differential pair must be terminated on the peripheral with LVPECL termination for the buffer to drive PXIe_SYNC100 so that when there is no peripheral or a peripheral that does not connect to PXIe_SYNC100, there is no SYNC100 signal being driven on the pair to that slot.

Figure 1-5. Distribution of PXI_CLK10, PXIe_CLK100, and PXIe_SYNC100

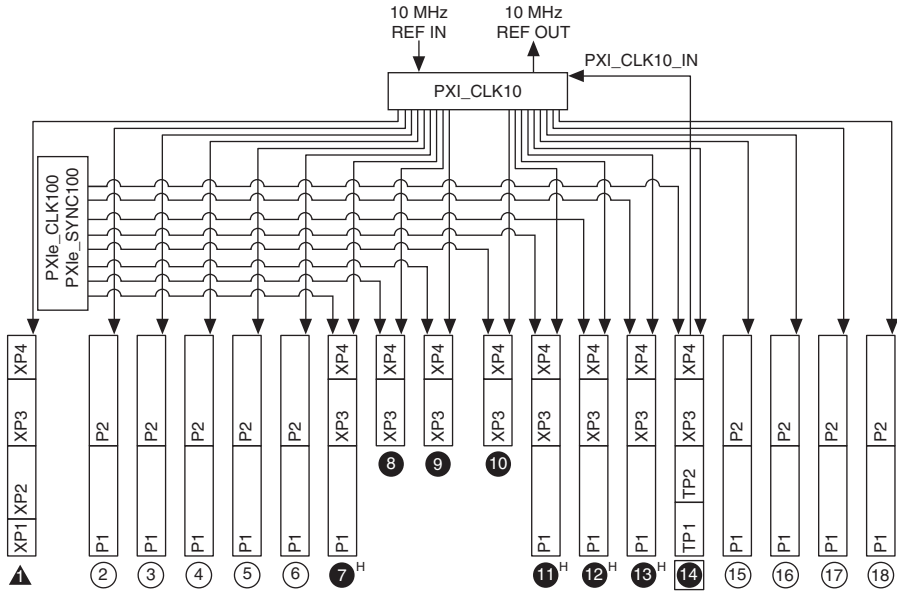

PXI_CLK10, PXIe_CLK100 and PXIe_SYNC100 have the default timing relationship described in Figure 1-6.

Figure 1-6. System Reference Clock Default Behavior

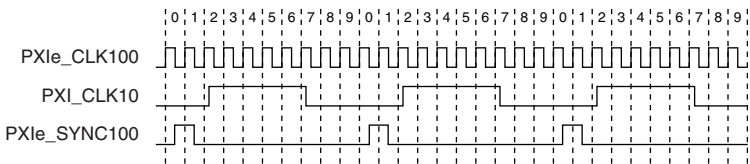

To synchronize the system to an external clock, you can drive PXI_CLK10 from an external source through the PXI_CLK10_IN pin on the System Timing Slot. Refer to Table B-8, *XP4 Connector Pinout for the System Timing Slot*, for the pinout. When a 10 MHz clock is detected on this pin, the backplane automatically phase-locks the PXI_CLK10, PXIe_CLK100, and PXIe_SYNC100 signals to this external clock and distributes these signals to the slots (refer to Figure 1-5 for the distribution of PXI_CLK10, PXIe_CLK100 and PXIe_SYNC100). Refer to Appendix A, *Specifications*, for the specification information for an external clock provided on the PXI_CLK10_IN pin of the system timing slot.

You also can drive a 10 MHz clock on the 10 MHz REF IN connector on the front of the chassis. When a 10 MHz clock is detected on this connector, the backplane automatically phase-locks the PXI_CLK10, PXIe_CLK100, and PXIe_SYNC100 signals to this external clock and distributes these signals to the slots (refer to Figure 1-5 for the distribution of PXI_CLK10, PXIe_CLK100 and PXIe_SYNC100). Refer to Appendix A, *Specifications*, for the specification information for an external clock provided on the 10 MHz REF IN connector on the rear panel of the chassis.

If the 10 MHz clock is present on both the PXI_CLK10_IN pin of the System Timing Slot and the 10 MHz REF IN connector on the front of the chassis, the signal on the System Timing Slot is selected. Refer to Table 1-1 which explains how the 10 MHz clocks are selected by the backplane.

Table 1-1. Backplane External Clock Input Truth Table

System Timing Slot PXI_CLK10_IN	Front Chassis Panel 10 MHz REF IN	Backplane PXI_CLK10, PXIe_CLK100 and PXIe_SYNC100
No clock present	No clock present	Backplane generates its own clocks
No clock present	10 MHz clock present	PXI_CLK10, PXIe_CLK100 and PXIe_SYNC100 all phase-locked to Rear Chassis Panel—10 MHz REF IN
10 MHz clock present	No clock present	PXI_CLK10, PXIe_CLK100 and PXIe_SYNC100 all phase-locked to System Timing Slot—PXI_CLK10_IN
10 MHz clock present	10 MHz clock present	PXI_CLK10, PXIe_CLK100 and PXIe_SYNC100 all phase-locked to System Timing Slot—PXI_CLK10_IN

A copy of the backplane's PXI_CLK10 is exported to the 10 MHz REF OUT connector on the front of the chassis. This clock is driven by an independent buffer. Refer to Appendix A, *Specifications*, for the specification information for the 10 MHz REF OUT signal on the front panel of the chassis.

PXle_SYNC_CTRL

PXle_SYNC100 is by default a 10 ns pulse synchronous to PXI_CLK10. The frequency of PXle_SYNC100 is $10/n$ MHz, where n is a positive integer. The default for n is 1, giving PXle_SYNC100 a 100 ns period. However, the backplane allows n to be programmed to other integers. For instance, setting $n = 3$ gives a PXle_SYNC100 with a 300 ns period while still maintaining its phase relationship to PXI_CLK10. The value for n may be set to any positive integer from 1 to 255.

The system timing slot has a control pin for PXle_SYNC100 called PXle_SYNC_CTRL for use when $n > 1$. Refer to Table B-7, *XP3 Connector Pinout for the System Timing Slot*, for system timing slot pinout. Refer to Appendix A, *Specifications*, for the PXle_SYNC_CTRL input specifications.

By default, a high-level detected by the backplane on the PXle_SYNC_CTRL pin causes a synchronous restart for the PXle_SYNC100 signal. On the next PXI_CLK10 edge the PXle_SYNC100 signal will restart. This will allow several chassis to have their PXle_SYNC100 in phase with each other. Refer to Figure 1-7 for timing details with this method.

Figure 1-7. PXle_SYNC100 at 3.33 MHz Using PXle_SYNC_CTRL as Restart

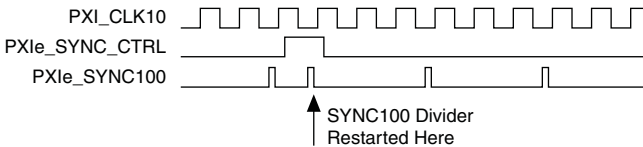

Installation and Configuration

This chapter describes how to prepare and operate the PXIe-1066DC chassis.

Before connecting the chassis to a power source, read this chapter and the *Read Me First: Safety and Electromagnetic Compatibility* document included with your kit.

Safety Information



Caution Before undertaking any troubleshooting, maintenance, or exploratory procedure, carefully read the following caution notices.

Protection equipment may be impaired if equipment is not used in the manner specified.

This equipment contains voltage hazardous to human life and safety, and is capable of inflicting personal injury.

- **Chassis Grounding**—The chassis requires a connection from the premise wire safety ground to the chassis ground. The earth safety ground must be connected during use of this equipment to minimize shock hazards. Refer to the [Connecting to Safety Ground and Power Source](#) section for instructions on connecting safety ground.
- **Live Circuits**—Operating personnel and service personnel *must* not remove protective covers when operating or servicing the chassis. Adjustments and service to internal components must be undertaken by qualified service technicians. During service of this product, the mains connector to the premise wiring must be disconnected. Dangerous voltages may be present under certain conditions; use extreme caution.
- **Explosive Atmosphere**—Do *not* operate the chassis in conditions where flammable gases are present. Under such conditions, this equipment is unsafe and may ignite the gases or gas fumes.
- **Part Replacement**—Only service this equipment with parts that are exact replacements, both electrically and mechanically. Contact National Instruments for replacement part information. Installation of parts with those that are not direct replacements may cause harm to personnel operating the chassis. Furthermore, damage or fire may occur if replacement parts are unsuitable.

- **Modification**—Do *not* modify any part of the chassis from its original condition. Unsuitable modifications may result in safety hazards.
- **Location**—The chassis is for use in stationary (non-moveable), restricted access locations such as a desk or bench, or for installation in a rack only. Installation and maintenance are to be performed by skilled/trained service persons.

Chassis Cooling Considerations

The PXIe-1066DC chassis is designed to operate on a bench or in an instrument rack. Regardless of the configuration you must provide the cooling clearances as outlined in the following sections.

Providing Adequate Clearance

Apertures in the top, bottom, and rear of the chassis facilitate power supply and module cooling. Air for module cooling enters through a fan intake in the bottom of the chassis and exits through the top of the chassis. Air for cooling the power supplies enters through the rear of the chassis and exits through the top of the chassis. Adequate clearance between the chassis and surrounding equipment or blockages must be maintained to ensure proper cooling of the chassis power supply as well as the modules plugged into the chassis. These clearances are outlined in Figure 2-1. The vent locations for the PXIe-1066DC chassis are shown in Figure 2-2. Failure to provide these clearances may result in thermal-related failures in the chassis or modules.

Figure 2-1. PXIe-1066DC Cooling Clearances

Dimensions are in inches (millimeters)

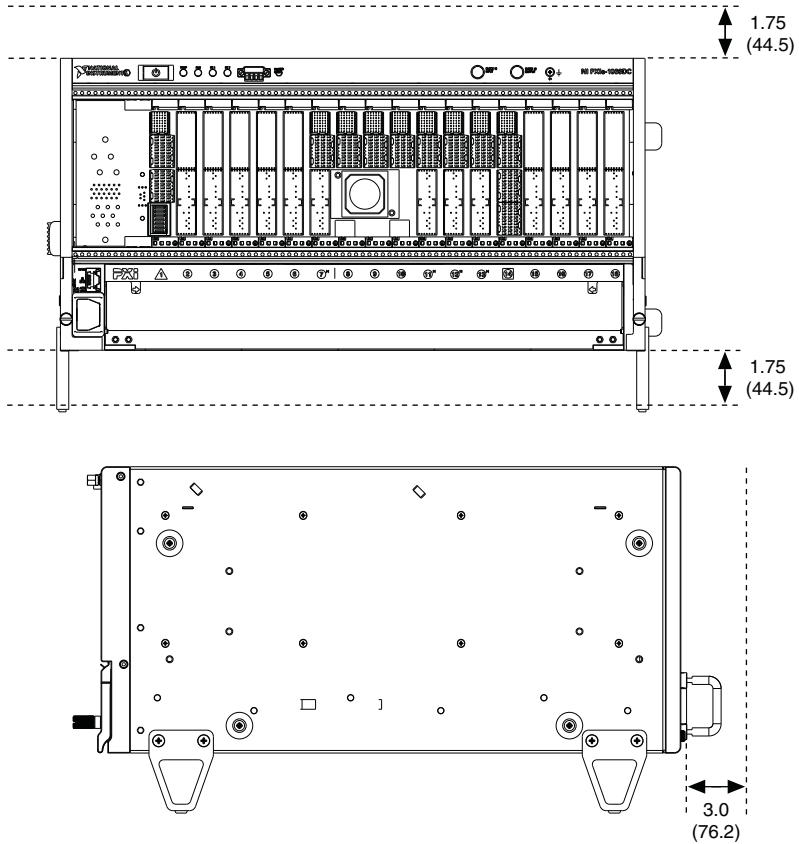
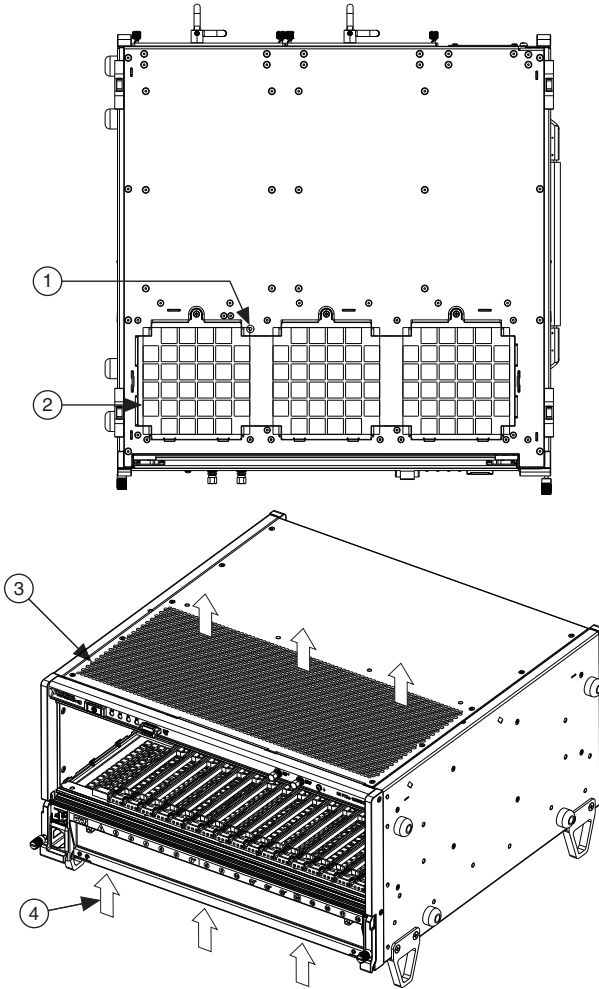

Figure 2-2. PXIe-1066DC Vents



- 1 Ambient Temperature Sensor
- 2 Air Intake Vents

- 3 Air Exhaust Vent
- 4 Airflow

Chassis Ambient Temperature Definition

The chassis fan control system uses the intake air temperature as the input for controlling fan speeds when in Auto Fan Speed mode. Because of this, the chassis ambient temperature is defined as the temperature of the air just outside of the fan intake vents on the bottom of the chassis. Note that this temperature may be higher than ambient room temperature depending on the surrounding equipment and/or blockages present. It is the user’s responsibility to ensure

that this ambient temperature does not exceed the rated ambient temperature as stated in Appendix A, *Specifications*. If the temperature exceeds the stated spec, the front-panel temperature LED blinks red, as discussed in the *Chassis LED Indicators* section of this chapter.

Setting Fan Speed

The fan-speed selector switch is on the rear panel of the PXIe-1066DC chassis. Refer to Figure 1-2, *Rear View of the PXIe-1066DC Chassis*, to locate the fan-speed selector switch. Select **High** for maximum cooling performance or **Auto** for improved acoustic performance. When set to **Auto**, the fan speed is determined by the chassis intake air temperature.

Installing Filler Panels

To maintain proper module cooling performance, install filler panels (provided with the chassis) in unused or empty slots. Secure with the captive mounting screws provided.

Installing Slot Blockers

The cooling performance of the chassis can be improved by installing optional slot blockers. Refer to ni.com for more details.

Fan Access Door Clearance

When installing the PXIe-1066DC chassis, you also must provide the proper clearance for the fan access door to open fully, as shown in Figure 2-3.

Figure 2-3. Fan Access Door Clearance

Dimensions are in inches (millimeters)

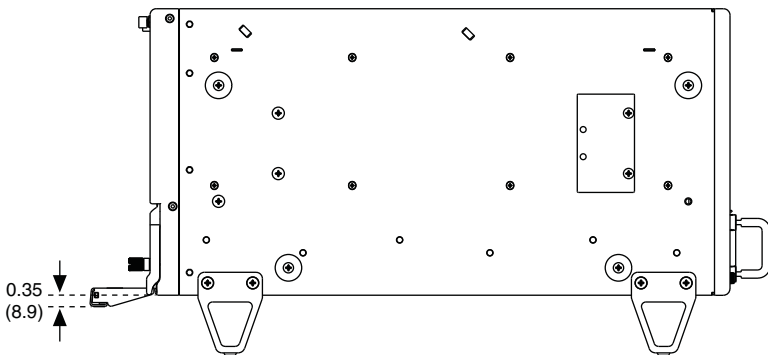

Rack Mounting

Rack mount applications require the optional rack mount kits available from National Instruments. Refer to the instructions supplied with the rack mount kits to install your PXIe-1066DC chassis in an instrument rack. Refer to Figure A-3, *NI Chassis Rack Mount Kit Components*.



Note You may want to remove the feet and handle from the PXIe-1066DC chassis when rack mounting. To do so, remove the screws holding the feet and handle in place.

Connecting to Safety Ground and Power Source

The PXIe-1066DC chassis has a single power connector that supplies input power to both chassis power supplies. The power connector is on the front panel, as shown in Figure 1-1, *Front View of the PXIe-1066DC Chassis (with Optional Filler Panels)*.

The PXIe-1066DC ships with a power cord that has an appliance coupler and leads for connection to the source. The cord requires custom termination. Figure 2-4 shows the cord connector pinout.

You can order an additional or replacement cord from National Instruments. Part number 782108-01 is a US/CAN approved 3 m, three-conductor, 18 AWG cord with leads and suitable for use in North America. Part Number 785863-01 is an international harmonized power cord, 3 m, three-conductor, 1.0mm² cord with leads and suitable for use in the EU and internationally. Installation must be done in accordance with local electric codes.



Caution Connecting Safety Ground (Protective Earth)

The PXIe-1066DC chassis must have a safety ground (protective earth), which is connected by the installer to the premise safety ground system for safe operation.

The supplied power cord has a green ground wire for this purpose. The safety ground method shall be reliable and meet applicable safety codes.

The Earth Ground Terminal on the rear of the chassis must be used where the the power cord is terminated via a standard power plug (e.g. IEC 60320, NEMA 5-15). Refer to Figure 1-2, *Rear View of the PXIe-1066DC Chassis*, to locate the Earth Ground Terminal. This provides a supplemental protective earthing connection to prevent shock hazards if the ground in the plug were to be interrupted. Complete the following steps to connect a protective conductor to this terminal:

1. Connect a 18 AWG wire to the Earth Ground Terminal using a grounding lug. The wire must have green insulation with a yellow stripe or must be noninsulated (bare). The lug must be sized for the M4 x 6 screw.
2. Attach the opposite end of the wire to permanent earth ground using toothed washers or a toothed lug.

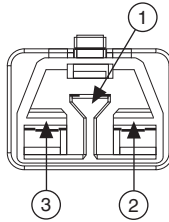
Figure 2-4. Power Connector

1 Protective Earth (Ground)	2 Power (-, Neutral)	3 Power (+, Hot)
-----------------------------	----------------------	------------------



Caution To ensure the specified EMC performance with a second chassis power supply, install a snap-on ferrite bead (NI part number 711849-01) onto the power cord as close to the input connector as possible.

You can order this ferrite bead directly from NI using the **Order By Part Number** link on the home page at ni.com. Order the following part number: 781233-02 EMI suppression ferrite, 10.2 mm (includes NI part number 711849-01 (Fair-Rite 0443167251, type 43, round cable, 10.2 mm/0.402 in. ID, 225 Ω @ 100 MHz)).

Power-On Test



Caution Do not install modules prior to performing the following power-on test.



Caution To completely remove power, you must disconnect all power cables.

The PXIe-1066DC chassis has two slots for inserting power supplies on the rear of the chassis. A power supply must be installed in one or both of these slots to power on the chassis.

Use the Inhibit Mode switch to power on the chassis or place it in standby mode. Set the Inhibit Mode switch on the back of the chassis to the Manual position. Observe that all fans become operational and that all chassis LEDs are steady green. Set the Inhibit Mode switch back to the Default position to allow the system controller to control the power supply.

Installing a PXI Express System Controller

This section contains general installation instructions for installing a PXI Express system controller in a PXIe-1066DC chassis. Refer to your PXI Express system controller user manual for specific instructions and warnings. To install a system controller, complete the following steps:

1. Ensure that the chassis is properly grounded to protect it from electrical damage while you install the system controller.
2. Install the system controller into the system controller slot (slot 1, indicated by the red card guides) by first placing the system controller PCB into the front of the card guides (top and bottom). Slide the system controller to the rear of the chassis, making sure that the injector/ejector handle is pushed down as shown in Figure 2-5.

Figure 2-5. Installing a PXI Express System Controller

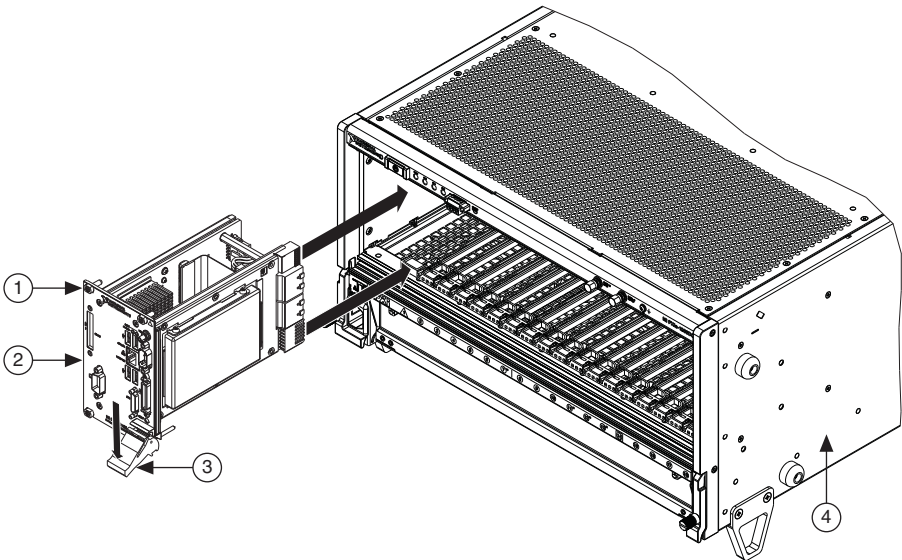

- | | |
|--|---------------------------|
| 1 System Controller Front Panel Mounting Screws (4x) | 3 Injector/Ejector Handle |
| 2 PXI Express System Controller | 4 PXIe-1066DC Chassis |

3. When you begin to feel resistance, pull up on the injector/ejector handle to seat the system controller fully into the chassis frame. Secure the system controller front panel to the chassis using the system controller front-panel mounting screws.
4. Connect the keyboard, mouse, and monitor to the appropriate connectors. Connect devices to ports as required by your system configuration.
5. Power on the chassis. Verify that the system controller boots. If the system controller does not boot, refer to your system controller user manual.

Figure 2-6 shows a PXI Express system controller installed in the system controller slot of a PXIe-1066DC chassis. You can place CompactPCI, CompactPCI Express, PXI, or PXI Express modules in other slots depending on the slot type.

Figure 2-6. PXI Express System Controller Installed in an PXIe-1066DC Chassis

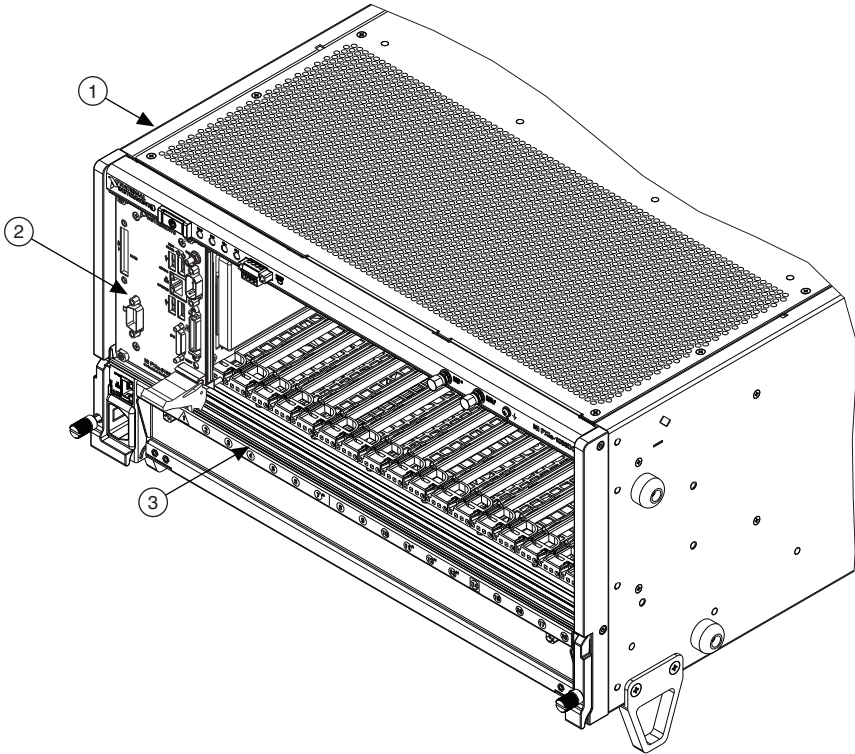

1 PXIe-1066DC Chassis

2 PXI Express System Controller

3 Injector/Ejector Rail

Installing Peripheral Modules



Caution The PXIe-1066DC chassis has been designed to accept a variety of peripheral module types in different slots. To prevent damage to the chassis, ensure that the peripheral module is being installed into a slot designed to accept it. Refer to Chapter 1, *Getting Started*, for a description of the various slot types.

This section contains general installation instructions for installing a peripheral module in a PXIe-1066DC chassis. Refer to your peripheral module user manual for specific instructions and warnings. To install a module, complete the following steps:

1. Ensure that the chassis is properly grounded to protect it from electrical damage while you install the module.
2. Ensure that the chassis is powered off.
3. Install a module into a chassis slot by first placing the module card PCB into the front of the card guides (top and bottom), as shown in Figure 2-7. Slide the module to the rear of the chassis, making sure that the injector/ejector handle is pushed down as shown in Figure 2-7.
4. When you begin to feel resistance, push up on the injector/ejector handle to fully seat the module into the chassis frame. Secure the module front panel to the chassis using the module front-panel mounting screws.

Figure 2-7. Installing PXI, PXI Express, or CompactPCI Peripheral Modules

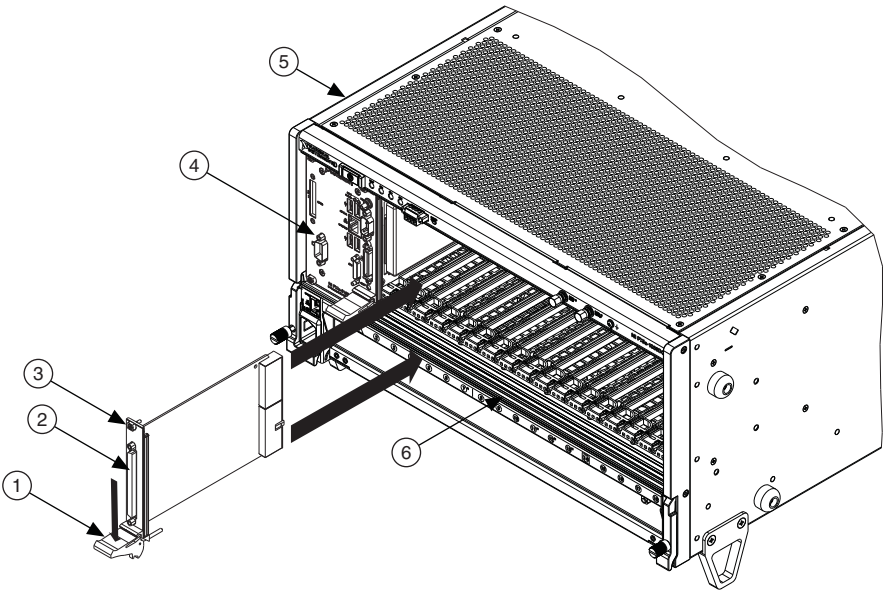

1	Injector/Ejector Handle	4	PXI Express System Controller
2	PXI Peripheral Module	5	PXIe-1066DC Chassis
3	Peripheral Module Front Panel Mounting Screws (2x)	6	Injector/Ejector Rail

Remote System Monitoring

The PXIe-1066DC chassis provides an Ethernet port on the front panel of the chassis. You can use this Ethernet port to monitor the chassis operating parameters remotely over a network. Refer to Figure 1-1, *Front View of the PXIe-1066DC Chassis (with Optional Filler Panels)*, to locate the Ethernet connector.

The Ethernet port on the chassis supports communication speeds of 10 Mbps and 100 Mbps. Contact your network administrator to determine whether your network supports DHCP. If your network uses DHCP, the network configuration is performed automatically.

To use the remote monitoring interface, connect one end of an Ethernet cable to your PXIe-1066DC chassis. Connect the other end of the cable to your Ethernet network.



Note The Ethernet controller can perform automatic crossover, thus eliminating the need for crossover cables.

Through the remote monitoring Ethernet interface of the chassis, you can access a web page with information about the current chassis operating parameters. You can access this page in most browsers. Enter the IP address or hostname currently assigned to the chassis into the browser's address bar. Figure 2-8 shows an example of the web page.

Figure 2-8. Chassis Configuration Web Page

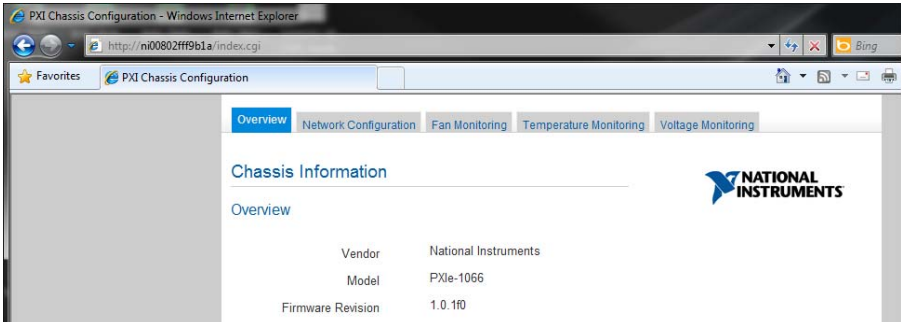

The Ethernet connector has two LEDs that indicate the current status of the Ethernet link. Table 2-1 describes the behavior of these LEDs.

Table 2-1. Ethernet LED Behavior

LED	State	Description
ACT/Link	Off	Link is not established.
	Steady green	Link is established.
	Blinking green	Chassis is communicating with another device on the network.
10/100	Off	10 Mbps data rate is selected.
	Steady green	100 Mbps data rate is selected

Default Configuration Settings

The chassis ships from the factory with the following default configuration settings:

- DHCP with Auto IP fallback
- Default hostname as printed on the product label

Chassis LED Indicators

The PXIe-1066DC chassis has four main LEDs on the front panel next to the Power Inhibit switch. Refer to Figure 1-1, *Front View of the PXIe-1066DC Chassis (with Optional Filler Panels)*, to locate these LEDs.

You can use the four main LEDs to determine the chassis operating status quickly. Table 2-2 describes the behavior of these LEDs.

Table 2-2. Main Chassis LED Behavior

LED	State	Description
Temperature Status	Off	Chassis is powered off.
	Steady green	Air intake temperature is within chassis operating range.
	Blinking red	Air intake temperature is outside of chassis operating range.
	Steady red	Air intake or exhaust temperature has reached critical limits.
Fan Status	Off	Chassis is powered off.
	Steady green	All chassis fans are enabled and operating normally.
	Blinking red	One or more chassis fans have failed, but chassis can continue to operate.
	Steady red	One or more chassis fans have failed, and chassis must shut itself down.
Power Supply 1 Status	Off	Power supply is not installed or is in standby.
	Steady green	Power supply is active, and all voltages are within normal operating ranges.
	Blinking red	Power supply is active, and at least one voltage is out of range.
	Steady red	Power supply has failed.
Power Supply 2 Status	Off	Power supply is not installed or is in standby.
	Steady green	Power supply is active, and all voltages are within normal operating ranges.
	Blinking red	Power supply is active, and at least one voltage is out of range.
	Steady red	Power supply has failed.

Each chassis fan assembly has an LED that shows the current health of that fan. Table 2-3 describes the chassis fan LED behavior.

Table 2-3. Chassis Fan LED Behavior

LED	State	Description
Individual Fan Status	Off	Fan is not enabled.
	Steady green	Fan is operating normally.
	Steady red	Fan has failed.

Each power supply also has an LED that shows the power supply’s current health. Table 2-4 describes the power supply LED behaviors.

Table 2-4. Power Supply LED Behavior

LEDs	State	Description
Individual Power Supply Status	Off	Power supply is in standby.
	Steady green	Power supply is operating normally.
	Steady red	Power supply has failed.

Remote Inhibit and Fault Monitoring

The PXIe-1066DC chassis supports remote inhibit and fault monitoring through a 4-pin terminal block on the chassis front panel. Refer to Figure 1-1, *Front View of the PXIe-1066DC Chassis (with Optional Filler Panels)*, to locate this terminal block. Table 2-5 shows the terminal block pinout.

Table 2-5. Remote Inhibit and Fault Connector Pinout

Pin	Signal
1	Remote Inhibit (active low)
2	Ground
3	Remote Fault (active high)
4	Ground

When the chassis Inhibit Mode switch is in the Manual position, you can use the Remote Inhibit signal to control the chassis power supplies. Refer to *Inhibit Mode Switch* for more details.

The Remote Fault signal is an output signal that is asserted high when any chassis fault is detected. You can use this signal to monitor the overall chassis health.

Inhibit Mode Switch

On the rear panel of the chassis there is an Inhibit Mode switch. Refer to Figure 1-2, *Rear View of the PXIe-1066DC Chassis*, for the location.

The Inhibit Mode switch should be in the **Default** position when normal power inhibit switch functionality is desired. If the user needs to power on a chassis without a system controller installed the switch should be in the **Manual** position.

When the Inhibit Mode switch is set to the **Manual** position, the power supplies are enabled, and you can use the Inhibit signal (active low) on pin 1 of the Remote Inhibit and Fault connector to power off the chassis. To power off the chassis remotely, connect the Inhibit pin (pin 1) to a Logic Ground pin (pin 2). As long as this connection exists, the chassis will remain off (standby); when you remove this connection, the chassis turns on.



Note For the Remote Inhibit signal to control the On/Off (standby) state of the chassis, the Inhibit Mode switch must be in the **Manual** position.

PXI_CLK10 Connectors

There are two SMA connectors on the front of the PXIe-1066DC chassis for PXI_CLK10. The connectors are labeled IN and OUT. You can use them for supplying the backplane with PXI_CLK10 or routing the backplane's PXI_CLK10 to another chassis. Refer to the *System Reference Clock* section of Chapter 1, *Getting Started*, for details about these signals.

PXI Express System Configuration with MAX

The PXI Platform Services software included with your chassis automatically identifies your PXI Express system components to generate a `pxiesys.ini` file. You can configure your entire PXI system and identify PXI-1 chassis through Measurement & Automation Explorer (MAX), included with your system controller. MAX creates the `pxiesys.ini` and `pxisys.ini` file, which define your PXI system parameters. MAX also provides an interface to route and reserve triggers so dynamic routing, through drivers such as DAQmx, avoids double-driving and potentially damaging trigger lines. For more information about routing and reserving PXI triggers, refer to KnowledgeBase **3TJDOND8** at ni.com/support.

The configuration steps for single or multiple-chassis systems are the same.

Figure 2-9. Multichassis Configuration in MAX

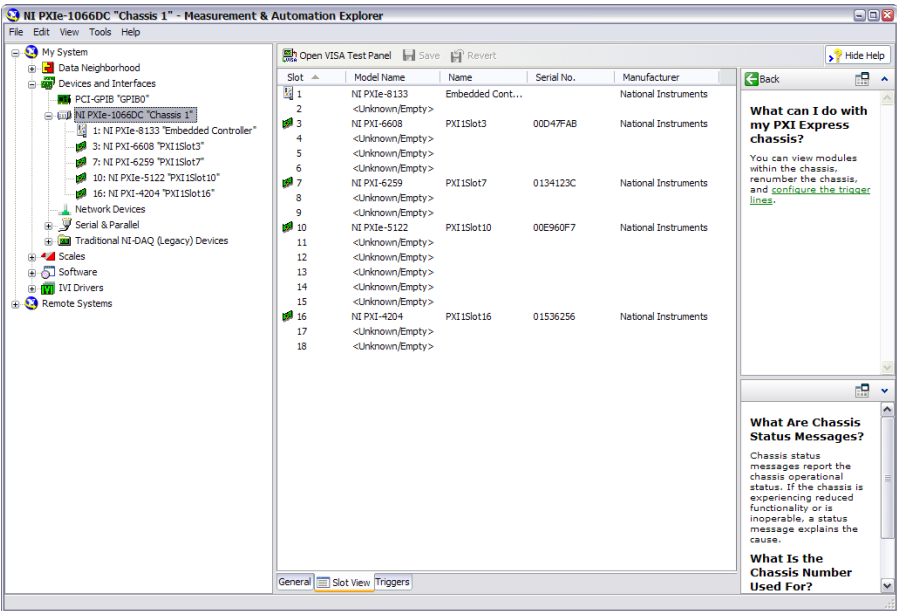

PXI-1 System Configuration

1. Launch MAX.
2. In the **Configuration** tree, click the **Devices and Interfaces** branch to expand it.
3. If the PXI system controller has not yet been configured, it is labeled **PXI System (Unidentified)**. Right-click this entry to display the pop-up menu, then select the appropriate system controller model from the **Identify As** submenu.
4. Click the PXI system controller. The chassis (or multiple chassis, in a multichassis configuration) is listed below it. Identify each chassis by right-clicking its entry, then selecting the appropriate chassis model through the **Identify As** submenu. Further expanding the **PXI System** branch shows all devices in the system that can be recognized by NI-VISA. When your system controller and all your chassis are identified, the required `pxisys.ini` file is complete.

The PXI specification allows for many combinations of PXI chassis and system modules. To assist system integrators, the manufacturers of PXI chassis and system modules must document the capabilities of their products. PXI Express devices must provide a driver and `.ini` file for identification. These files are provided as part of the PXI Platform Services software included with your system controller. The minimum documentation requirements for PXI-1 are contained in `.ini` files, which consist of ASCII text. System integrators, configuration utilities, and device drivers can use these `.ini` files.

The capability documentation for a PXI-1 chassis is contained in a `chassis.ini` file provided by the chassis manufacturer. The information in this file is combined with information about the system controller to create a single PXI-1 system initialization file called `pxisys.ini` (PXI System Initialization). The NI system controller uses MAX to generate the `pxisys.ini` file from the `chassis.ini` file.

Device drivers and other utility software read the `pxiesys.ini` and `pxisys.ini` file to obtain system information. For detailed information about initialization files, refer to the PXI specification at www.pxisa.org.

Trigger Configuration in MAX

Each chassis has one or more trigger buses, each with eight lines numbered 0 through 7 that can be reserved and routed statically or dynamically. Static reservation *pre-allocates* a trigger line to prevent its configuration by a user program. Dynamic reservation/routing/deallocation is *on the fly* within a user program based upon National Instruments APIs such as NI-DAQmx. Static reservation of trigger lines can be implemented by the user in MAX through the **Triggers** tab. Reserved trigger lines will not be used by PXI modules dynamically configured by programs such as NI-DAQmx. This prevents the instruments from double-driving the trigger lines, possibly damaging devices in the chassis. In the default configuration, trigger lines on each bus are independent. For example, if trigger line 3 is asserted on trigger bus 0, by default it will not be automatically asserted on any other trigger bus.

Complete the following steps to reserve these trigger lines in MAX.

1. In the Configuration tree, click on the PXI chassis branch you want to configure.
2. Then, in the right-hand pane, toward the bottom, click on the **Triggers** tab.
3. Select which trigger lines you would like to statically reserve.
4. Click the **Apply** button.

PXI Trigger Bus Routing

The PXIe-1066DC chassis can route triggers from one bus to others within the same chassis using the **Trigger Routing** tab in MAX, as shown in Figure 2-9.



Note Selecting any non-disabled routing automatically reserves the line in all trigger buses being routed to. If you are using NI-DAQmx, it will reserve and route trigger lines for you, so you won't have to route trigger lines manually.

Complete the following steps to configure trigger routings in MAX.

1. In the **Configuration** tree, select the chassis in which you want to route trigger lines.
2. In the right-hand pane, select the **Trigger Routing** tab near the bottom.
3. For each trigger line, select **Route Right**, **Route Outward From Middle**, or **Route Left** to route triggers on that line in the described direction, or select **Disabled** for the default behavior with no manual routing.
4. Click the **Apply** button.

Using System Configuration and Initialization Files

The PXI Express specification allows many combinations of PXI Express chassis and system modules. To assist system integrators, the manufacturers of PXI Express chassis and system modules must document the capabilities of their products. The minimum documentation requirements are contained in `.ini` files, which consist of ASCII text. System integrators, configuration utilities, and device drivers can use these `.ini` files.

The capability documentation for the PXIe-1066DC chassis is contained in the `chassis.ini` file on the software media that comes with the chassis. The information in this file is combined with information about the system controller to create a single system initialization file called `pxisys.ini` (PXI System Initialization). The system controller manufacturer either provides a `pxisys.ini` file for the particular chassis model that contains the system controller or provides a utility that can read an arbitrary `chassis.ini` file and generate the corresponding `pxisys.ini` file. System controllers from NI provide the `pxisys.ini` file for the PXIe-1066DC chassis, so you should not need to use the `chassis.ini` file. Refer to the documentation provided with the system controller or to ni.com/support for more information on `pxisys.ini` and `chassis.ini` files.

Device drivers and other utility software read the `pxisys.ini` file to obtain system information. The device drivers should have no need to directly read the `chassis.ini` file. For detailed information regarding initialization files, refer to the PXI Express specification at www.pxisa.org.

Maintenance

This chapter describes basic maintenance procedures you can perform on the PXIe-1066DC chassis.



Caution Disconnect the power cable prior to servicing a PXIe-1066DC chassis.

Service Interval

Clean dust from the chassis exterior (and interior) as needed, based on the operating environment. Periodic cleaning increases reliability.

Preparation

The information in this section is designed for use by qualified service personnel. Read the *Read Me First: Safety and Electromagnetic Compatibility* document included with your kit before attempting any procedures in this chapter.



Caution Many components within the chassis are susceptible to static discharge damage. Service the chassis only in a static-free environment. Observe standard handling precautions for static-sensitive devices while servicing the chassis. *Always* wear a grounded wrist strap or equivalent while servicing the chassis.

Cleaning

Cleaning procedures consist of exterior and interior cleaning of the chassis. Refer to your module user documentation for information on cleaning the individual CompactPCI or PXI Express modules.



Caution *Always* disconnect all power cables before cleaning or servicing the chassis.

Interior Cleaning

Use a dry, low-velocity stream of air to clean the interior of the chassis. Use a soft-bristle brush for cleaning around components.

Exterior Cleaning

Clean the exterior surfaces of the chassis with a dry lint-free cloth or a soft-bristle brush. If any dirt remains, wipe with a cloth moistened in a mild soap solution. Remove any soap residue by wiping with a cloth moistened with clear water. Do not use abrasive compounds on any part of the chassis.



Caution Avoid getting moisture inside the chassis during exterior cleaning, especially through the top vents. Use just enough moisture to dampen the cloth.



Caution Do *not* wash the front- or rear-panel connectors or switches. Cover these components while cleaning the chassis.



Caution Do *not* use harsh chemical cleaning agents; they may damage the chassis. Avoid chemicals that contain benzene, toluene, xylene, acetone, or similar solvents.

Replacing a Modular Power Supply

This section describes how to remove and install a modular power supply for the PXIe-1066DC chassis.



Caution Do not use a power supply from another chassis. Doing so may damage your chassis and the power supply. You *must* ensure the chassis is properly grounded after any maintenance. Refer to Chapter 2, [Connecting to Safety Ground and Power Source](#), for instructions on connecting safety ground.

Removal

The PXIe-1066DC power supply (part number 782106-01) is a replacement part for the PXIe-1066DC chassis. Before attempting to replace a power supply, verify that there is adequate clearance behind the chassis.

The power supplies for this chassis are redundant and hot swappable. If both power supplies are installed and functional, you can remove either without disconnecting main power from the system. If both power supplies are installed, and one has failed, you can remove the failed supply without disconnecting main power from the system. If only one power supply is installed and functional, you must remove main power from the system by disconnecting the power cable from the power connector on the chassis front panel.

Complete the following steps to remove a power supply from the rear of the chassis, as shown in Figure 3-1:



Caution Before handling the power supply, allow the fan to stop spinning.

1. Remove the two screws on the rear of the power supply with a flat-blade screwdriver.
2. Extend the collapsible handle and pull the power supply out of the chassis.

Figure 3-1. Removing Power Supply from PXIe-1066DC Chassis

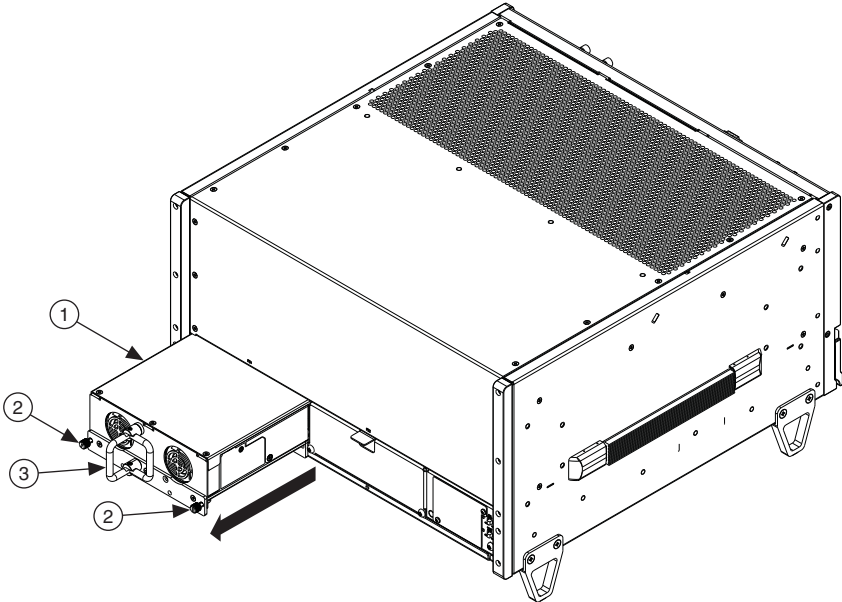

1 Power Supply

2 Captive Screw

3 Collapsible Handle

If access to the rear of the chassis is not available, you still can remove the power supplies by removing the entire power drawer from the chassis. The power drawer is shown in Figure 3-2.

Figure 3-2. PXIe-1066DC Power Drawer

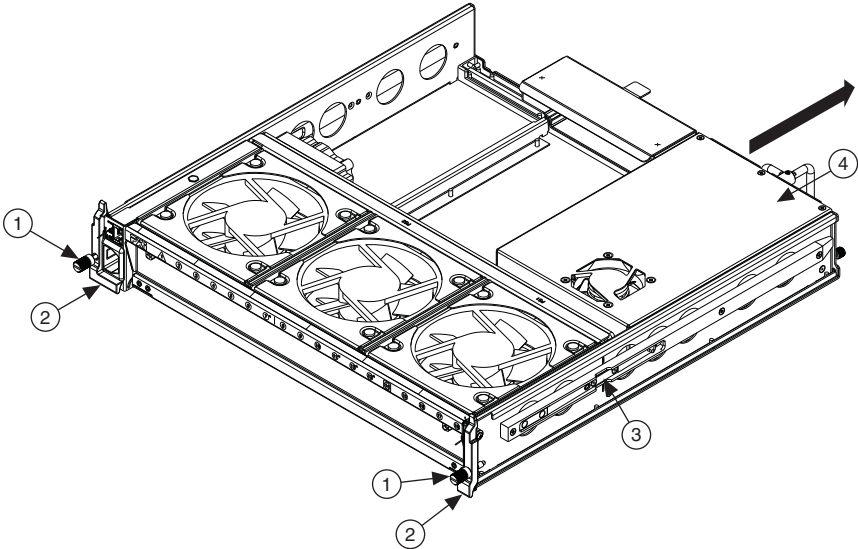

- | | | | | | | | |
|---|---------------|---|--------------------|---|------------|---|--------------|
| 1 | Captive Screw | 2 | Power Drawer Lever | 3 | Side Latch | 4 | Power Supply |
|---|---------------|---|--------------------|---|------------|---|--------------|



Note If you are using the PXIe-1066DC and NI SC Express modules with front mounting terminal blocks together, you must remove the SC Express module front mount terminal blocks to access the power drawer. Refer to your module documentation for more information about removing the terminal blocks.

Complete the following steps to remove the power drawer:



Caution You must disconnect AC or DC power before removing the power drawer.

1. Disconnect AC or DC power by pressing the release button on the power cord.
2. Loosen the drawer lever captive screws with a flat-blade screwdriver until the threads disengage from the chassis frame.
3. Rotate the drawer levers to eject the drawer from the chassis frame.
4. Pull the drawer about halfway out until the side latches engage.
5. Press in the side latches on both sides to release the drawer and continue to pull out the drawer.



Caution Before handling the power supply, allow the fan to stop spinning.

6. Place the drawer on a table surface to remove the power supply.
7. Remove the two screws on the rear of the power supply with a flat-blade screwdriver. (Refer to Figure 3-1.)
8. Extend the collapsible handle and pull the power supply out of the chassis. (Refer to Figure 3-1.)

Installation

Ensure there is no visible damage to the new power supply before installing it. Verify that there is no foreign material inside the connector on the new power supply.

The power supplies for this chassis are redundant and hot swappable. If one power supply already is installed and functional, you can install the second power supply without first disconnecting AC or DC power from the system. If no power supplies are installed or functional in the system, you must remove main power from the system by disconnecting the power cable from the power connector on the chassis front panel.

Complete the following steps to install a power supply from the rear of the chassis:

1. Slide the power supply into an empty slot with the connector facing toward the chassis until it engages.
2. Fold down the collapsible handle on the power supply.
3. Tighten the two captive screws on the rear of the power supply to 11.5 lb · in. torque with a flat-blade screwdriver.

If access to the rear of the chassis is not available, you still can install power supplies by removing the entire power drawer from the chassis. The power drawer is shown in Figure 3-2.



Note If you are using the PXIe-1066DC and NI SC Express modules with front mounting terminal blocks together, you must remove the SC Express module front mount terminal blocks to access the power drawer. Refer to your module documentation for more information about removing the terminal blocks.

Complete the following steps to remove the power drawer:



Caution You must disconnect AC or DC power before removing the power drawer.

1. Disconnect AC or DC power by pressing the release button on the power cord.
2. Loosen the drawer lever captive screws with a flat-blade screwdriver until the threads disengage from the chassis frame.
3. Rotate the drawer levers to eject the drawer from the chassis frame.
4. Pull the drawer about halfway out until the side latches engage.

5. Press in the side latches on both sides to release the drawer and continue to pull out the drawer.



Caution Before handling the power supply, allow the fan to stop spinning.

6. Place the drawer on a table surface to install the power supply.
7. Slide the power supply into an empty slot with the connector facing toward the chassis until it engages.
8. Fold down the collapsible handle on the power supply.
9. Tighten the two captive screws on the rear of the power supply to 11.5 lb · in. torque with a flat-blade screwdriver.
10. Reinstall the power drawer. When reinstalling the drawer, tighten the drawer lever captive screws to 11.5 lb · in. torque.

Replacing a Modular Fan Assembly

This section describes how to remove and install a modular fan assembly for the PXIe-1066DC chassis.



Caution Do not use a fan assembly from another chassis. Doing so may damage your chassis and the fan assembly.

Removal

The PXIe-1066DC fan assembly (part number 782107-01) is a replacement part for the PXIe-1066DC chassis. Before attempting to replace a fan assembly, verify that there is adequate clearance in front of the chassis.

The fans for this chassis are redundant and hot swappable. You can remove the fans with main AC or DC power connected to the system.



Caution Use care when selecting which fans to remove, as an undesired system shut down can occur. Do not remove both fans from the same column, as this triggers a system shutdown.



Caution Likewise, do not remove the working fan from the same column as a failed fan, as this also triggers a chassis shutdown.



Caution If all fans are installed and operating normally, you can remove any fan without causing the system to shut down.

Figure 3-3 shows the PXIe-1066DC chassis with a fan assembly removed.

Figure 3-3. PXIe-1066DC Chassis with Fan Assembly Removed

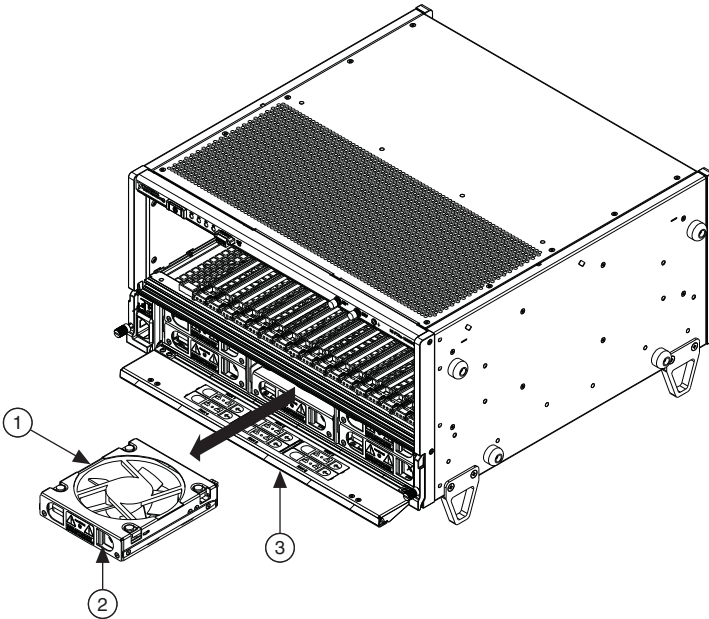

1 Modular Fan Assembly

2 Fan Latch

3 Fan Door

Complete the following steps to remove a fan assembly:

1. Open the fan door by sliding the door latches inward and rotating the door down.
2. Locate the fan to be removed. A red LED indicates a failed fan.



Caution If the fan is still spinning, allow the fan to stop before handling. (The fan will not stop as long as it is in the airflow path.)

3. Press in the fan latch until it disengages and allows removal by pulling the fan module forward.

Installation

Ensure there is no visible damage to the new fan assembly before installing it. Verify that there is no foreign material inside the connector on the new fan assembly.

The fans for this chassis are redundant and hot swappable. You can install any fan with main DC power connected to the system.

Complete the following steps to install a fan assembly:

1. Open the fan door by sliding the door latches inward and rotating the door down.
2. Slide the fan module into an empty fan slot with the connector facing the chassis until it latches.
3. Verify that the fan is properly installed by pulling it forward with a light force without pressing the latch. If the fan does not slide out without pressing in the latch, it is installed correctly.
4. Close the fan door.

Specifications

This appendix contains specifications for the PXIe-1066DC chassis.



Caution Specifications are subject to change without notice.

Electrical

Input voltage range	210 to 300 VDC 100 to 240 VAC
Operating voltage range.....	210 to 300 VDC 90 to 264 VAC
Input current rating	3.5 to 6.0 A (DC) 12 to 6 A (AC)
AC input frequency range.....	47 to 63 Hz
Over-current protection	Two 15 A input fuses, nonreplaceable, One 10 A power supply fuse, nonreplaceable
Efficiency.....	70% typical
Power disconnect.....	The power cable provides main power disconnect. The front panel power switch causes the internal chassis power supply to provide DC power to the CompactPCI/PXI Express backplane. You also can use the front panel terminal block 4-pin connector and power mode switch to control the internal chassis power supply.

DC Output

DC current capacity (I_{MP})

Voltage	Maximum Current
+3.3 V	50 A
+5 V	42 A
+12 V	50 A
-12 V	4 A
5 V _{AUX}	1.5 A



Note Maximum combined +12 V and -12 V power is 588 W.



Note Maximum total available power is 880 W.

Backplane slot current capacity

Slot	+5 V	V(I/O)	+3.3 V	+12 V	-12 V	5 V _{AUX}
System Controller Slot	15 A	—	15 A	30 A	—	1 A
System Timing Slot	—	—	6 A	4 A	—	1 A
Hybrid Peripheral Slot with PXI-1 Peripheral	6 A	5 A	6 A	1 A	1 A	—
Hybrid Peripheral Slot with PXI-5 Peripheral	—	—	6 A	4 A	—	1 A
PXI-1 Peripheral Slot	6 A	11 A	6 A	1 A	1 A	—



Note Total system slot current should not exceed 45 A.



Note PCI V(I/O) pins in PXI-1 peripheral slots and hybrid peripheral slots are connected to +5 V.



Note The maximum power dissipated in the system slot should not exceed 140 W.



Note The maximum power dissipated in a peripheral slot should not exceed 38.25 W.

Load regulation

Voltage	Load Regulation
+3.3 V	<5%
+12 V	<5%
+5 V	<5%
-12 V	<5%

Maximum ripple and noise (20 MHz bandwidth)

Voltage	Maximum Ripple and Noise
+3.3 V	50 mV _{pp}
+12 V	120 mV _{pp}

Voltage	Maximum Ripple and Noise
+5 V	50 mV _{pp}
-12 V	120 mV _{pp}

Over-current protection	All outputs protected from short circuit and overload with automatic recovery
Over-voltage protection 3.3 V and 5 V	Clamped at 25 to 40% above nominal output voltage
Power supply MTTR	Replacement in under 1 minute

Chassis Cooling

Module cooling system PXIe-1066DC	Force air circulation (positive pressurization) through six 150 cfm fans (three sets of dual stacked fans) with High/Auto speed selector.
Slot airflow direction	Bottom of module to top of module
Module cooling intake	Bottom of chassis
Module cooling exhaust	Along top of chassis
Power supply cooling system	Forced air circulation through integrated fan
Power supply cooling intake	Rear of chassis
Power supply cooling exhaust	Top of chassis

Environmental

Maximum altitude	4600 m (570 mbar) (at 25 °C ambient)
------------------------	--------------------------------------



Note Fan speed selector must be set to **High** to meet the maximum altitude specification.

Pollution Degree	2
------------------------	---

For indoor use only.

Operating Environment

Ambient temperature range	0 to 50 °C (Tested in accordance with IEC 60068-2-1 and IEC 60068-2-2. Meets MIL-PRF-28800F Class 3 temperature limits.)
Relative humidity range	10 to 90%, noncondensing (Tested in accordance with IEC 60068-2-56.)

Storage Environment

Ambient temperature range	-40 to 71 °C (Tested in accordance with IEC 60068-2-1 and IEC 60068-2-2. Meets MIL-PRF-28800F Class 3 temperature limits.)
Relative humidity range.....	5 to 95%, noncondensing (Tested in accordance with IEC 60068-2-56.)

Shock and Vibration

Operational shock	30 g peak, half-sine, 11 ms pulse (Tested in accordance with IEC 60068-2-27. Meets MIL-PRF-28800F Class 2 limits.)
-------------------------	---

Random Vibration

Operating	5 to 500 Hz, 0.3 grms
Nonoperating	5 to 500 Hz, 2.4 grms (Tested in accordance with IEC 60068-2-64. Nonoperating test profile exceeds the requirements of MIL-PRF-28800F, Class 3.)



Caution When using a single power supply unit, you must use a power supply filler panel (NI part number 784057-01) in the empty slot to meet operational shock and vibration specifications.

Acoustic Emissions

Sound Pressure Level (at Operator Position)

(Tested in accordance with ISO 7779. Meets MIL-PRF-28800F requirements.)

Auto fan (up to ~30 °C ambient)	57.0 dBA
High fan	69.0 dBA

Sound Power

Auto fan (up to ~30 °C ambient)	61.7 dBA
High fan	79.3 dBA



Note Specifications are subject to change without notice.

Safety

This product is designed to meet the requirements of the following standards of safety for information technology equipment:

- IEC 61010-1, EN 61010-1
- UL 61010-1, CSA 61010-1



Note For UL and other safety certifications, refer to the product label or the [Online Product Certification](#) section.

Electromagnetic Compatibility

This product meets the requirements of the following EMC standards for electrical equipment for measurement, control, and laboratory use:

- EN 61326-1 (IEC 61326-1): Class A emissions; Basic immunity
- EN 55011 (CISPR 11): Group 1, Class A emissions
- AS/NZS CISPR 11: Group 1, Class A emissions
- FCC 47 CFR Part 15B: Class A emissions
- ICES-001: Class A emissions



Note In the United States (per FCC 47 CFR), Class A equipment is intended for use in commercial, light industrial, and heavy industrial locations. In Europe, Canada, Australia, and New Zealand (per CISPR 11), Class A equipment is intended for use only in heavy industrial locations.



Note Group 1 equipment (per CISPR 11) is any industrial, scientific, or medical equipment that does not intentionally generate radio frequency energy for the treatment of material or inspection/analysis purposes.



Note For EMC declarations and certifications and additional information, refer to the [Online Product Certification](#) section.

CE Compliance

This product meets the essential requirements of applicable European Directives as follows:

- 2014/35/EC; Low-Voltage Directive (safety)
- 2014/13/EC; Electromagnetic Compatibility Directive (EMC)

Online Product Certification

Refer to the product Declaration of Conformity (DoC) for additional regulatory compliance information. To obtain product certifications and the DoC for this product, visit ni.com/certification, search by model number or product line, and click the appropriate link in the Certification column.

Environmental Management

NI is committed to designing and manufacturing products in an environmentally responsible manner. NI recognizes that eliminating certain hazardous substances from our products is beneficial to the environment and to NI customers.

For additional environmental information, refer to the *Minimize Our Environmental Impact* web page at ni.com/environment. This page contains the environmental regulations and directives with which NI complies, as well as other environmental information not included in this document.

Waste Electrical and Electronic Equipment (WEEE)



EU Customers At the end of the product life cycle, all products *must* be sent to a WEEE recycling center. For more information about WEEE recycling centers, National Instruments WEEE initiatives, and compliance with WEEE Directive 2002/96/EC on Waste and Electronic Equipment, visit ni.com/environment/weee.

电子信息产品污染控制管理办法（中国 RoHS）



中国客户 National Instruments 符合中国电子信息产品中限制使用某些有害物质指令 (RoHS)。关于 National Instruments 中国 RoHS 合规性信息，请登录 ni.com/environment/rohs_china。(For information about China RoHS compliance, go to ni.com/environment/rohs_china.)

Backplane

Size.....	3U-sized; one system slot (with three system expansion slots) and 17 peripheral slots. Compliant with IEEE 1101.10 mechanical packaging. PXI Express Specification compliant. Accepts both PXI Express and CompactPCI (PICMG 2.0 R 3.0) 3U modules.
Backplane bare-board material	UL 94 V-0 Recognized
Backplane connectors	Conforms to IEC 917 and IEC 1076-4-101, and are UL 94 V-0 rated

System Synchronization Clocks (PXI_CLK10, PXIe_CLK100, PXIe_SYNC100)

10 MHz System Reference Clock: PXI_CLK10

Maximum slot-to-slot skew	500 ps
Accuracy	±25 ppm max. (guaranteed over the operating temperature range)
Maximum jitter	5 ps RMS phase-jitter (10 Hz to 1 MHz range)
Duty-factor.....	45% to 55%
Unloaded signal swing.....	3.3 V ±0.3 V



Note For other specifications, refer to the *PXI-1 Hardware Specification*.

100 MHz System Reference Clock: PXIe_CLK100 and PXIe_SYNC100

Maximum slot-to-slot skew	100 ps
Accuracy	±25 ppm max. (guaranteed over the operating temperature range)
Maximum jitter	3 ps RMS phase-jitter (10 Hz to 12 kHz range) 2 ps RMS phase-jitter (12 kHz to 20 MHz range)
Duty-factor for PXIe_CLK100	45% to 55%
Absolute single-ended voltage swing (When each line in the differential pair has 50 Ω termination to 1.30 V or Thévenin equivalent)	400 to 1000 mV



Note For other specifications, refer to the *PXI-5 PXI Express Hardware Specification*.

External 10 MHz Reference Out (SMA on front panel of chassis)

Accuracy	±25 ppm max (guaranteed over the operating temperature range)
Maximum jitter	5 ps RMS phase-jitter (10 Hz to 1 MHz range)
Output amplitude	1 V_{pp} ±20% square-wave into 50 Ω 2 V_{pp} unloaded
Output impedance	50 Ω ±5 Ω

External Clock Source

Frequency	10 MHz ±100 PPM
Input amplitude	
Front-panel SMA	200 mV _{pp} to 5 V _{pp} square-wave or sine-wave
System timing slot	
PXI_CLK10_IN	5 V or 3.3 V TTL signal
Front-panel SMA input impedance	50 Ω ±5 Ω
Maximum jitter introduced by backplane	1 ps RMS phase-jitter (10 Hz to 1 MHz range)

PXIe_SYNC_CTRL

V_{IH}	2.0 to 5.5 V
V_{IL}	0 to 0.8 V

PXI Star Trigger

Maximum slot-to-slot skew	250 ps
Backplane characteristic impedance.....	65 Ω ±10%



Note For PXI slot to PXI Star mapping refer to the *System Timing Slot* section of Chapter 1, *Getting Started*.

For other specifications refer to the *PXI-1 Hardware Specification*.

PXI Differential Star Triggers (PXIe-DSTARA, PXIe-DSTARB, PXIe-DSTARC)

Maximum slot-to-slot skew	150 ps
Maximum differential skew	25 ps
Backplane differential impedance.....	100 Ω ±10%



Note For PXI Express slot to PXI_DSTAR mapping refer to the *System Timing Slot* section of Chapter 1, *Getting Started*.

For other specifications, the PXIe-1066DC complies with the *PXI-5 PXI Express Hardware Specification*.

Mechanical

Overall dimensions

Standard chassis

Height.....	10.59 in. (268.7 mm)
Width.....	18.39 in. (467.1 mm)
Depth.....	18.76 in. (476.5 mm)



Note 1.84 in. (46.8 mm) is added to height when feet are installed.

Weight

With two power supplies.....	37.6 lb
With single power supply	31.5 lb

Chassis materials.....	Sheet Aluminum (5052-H32, 3003-H14, and 6061-T6), Extruded Aluminum (6060-T6), and Cold Rolled Steel, PC-ABS, Santoprene, Nylon
------------------------	---

Finish	Conductive Clear Iridite on Aluminum Electroplated Nickel on Cold Rolled Steel Polyurethane Enamel
--------------	---

Figures A-1 and A-2 show the PXIe-1066DC chassis dimensions. The holes shown are for the installation of the optional rack mount kits. You can install those kits on the front or rear of the chassis, depending on which end of the chassis you want to face toward the front of the instrument cabinet. Notice that the front and rear chassis mounting holes (size M4) are symmetrical.

Figure A-1. PXIe-1066DC Chassis Dimensions (Front and Side)

Dimensions are in inches (millimeters)

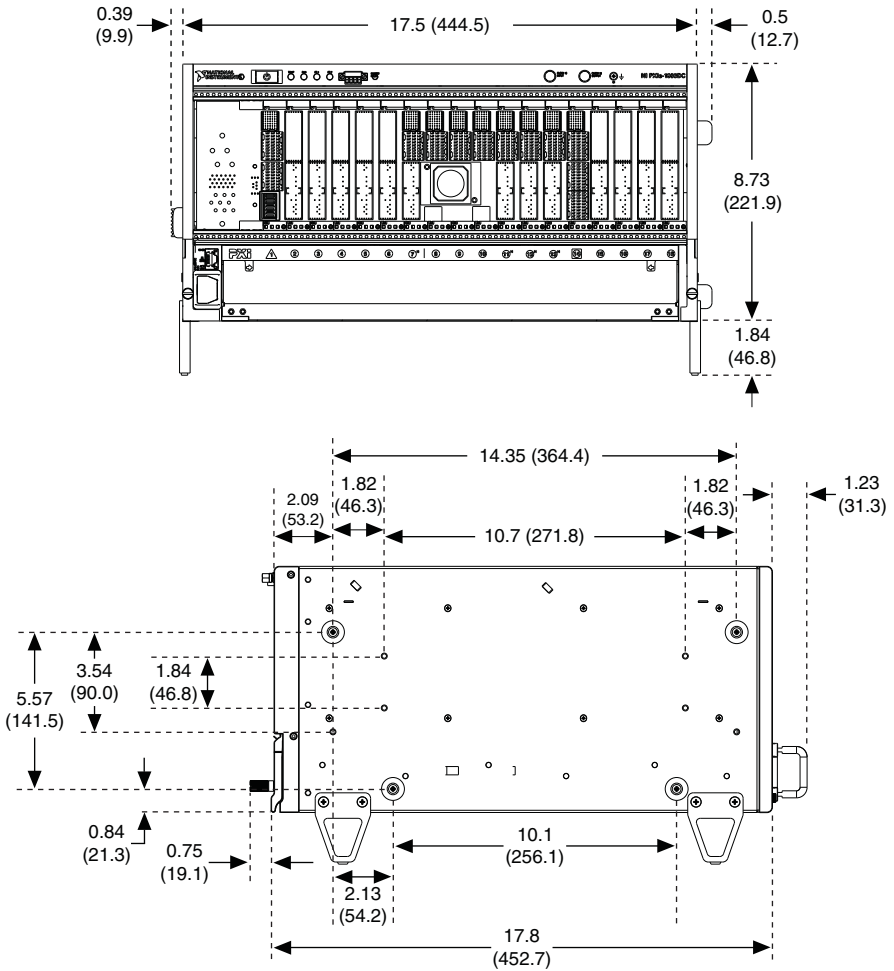

Figure A-2. PXIe-1066DC Chassis Dimensions (Bottom)

Dimensions are in inches (millimeters)

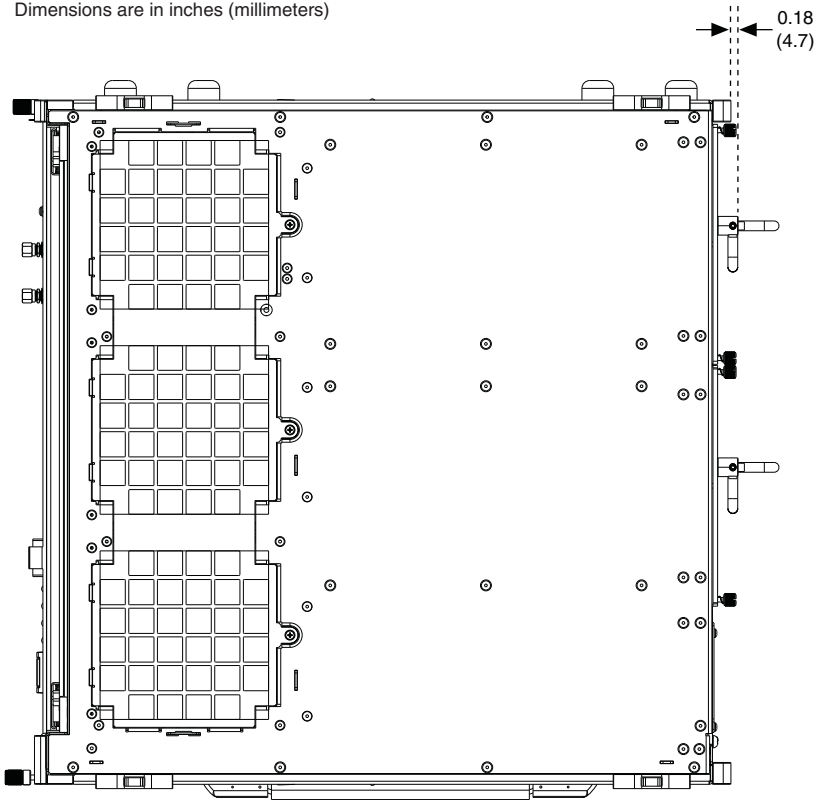
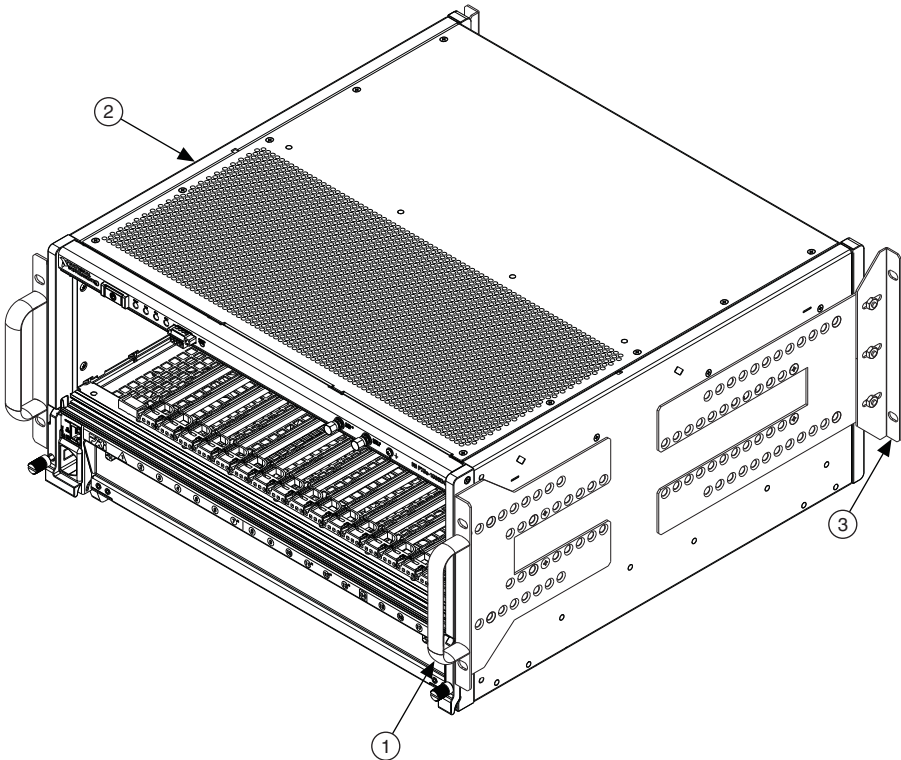

Figure A-3 shows the chassis rack mount kit components.

Figure A-3. NI Chassis Rack Mount Kit Components



1 Front Rack Mount Kit

2 NI Chassis

3 Optional Rear Rack Mount Kit



Note For more information about rack mounting the PXIe-1066DC chassis, refer to the printed installation guide included with your rack mount kit.

Pinouts

This appendix describes the connector pinouts for the PXIe-1066DC chassis backplane.

Table B-1 shows the XP1 connector pinout for the System Controller slot.

Table B-2 shows the XP2 connector pinout for the System Controller slot.

Table B-3 shows the XP3 connector pinout for the System Controller slot.

Table B-4 shows the XP4 connector pinout for the System Controller slot.

Table B-5 shows the TP1 connector pinout for the System Controller slot.

Table B-6 shows the TP2 connector pinout for the System Timing slot.

Table B-7 shows the XP3 connector pinout for the System Timing slot.

Table B-8 shows the XP4 connector pinout for the System Timing slot.

Table B-9 shows the P1 connector pinout for the peripheral slots.

Table B-10 shows the P2 connector pinout for the peripheral slots.

Table B-11 shows the P1 connector pinout for the Hybrid peripheral slots.

Table B-12 shows the XP3 connector pinout for the Hybrid peripheral slots.

Table B-13 shows the XP4 connector pinout for the Hybrid peripheral slots.

For more detailed information, refer to the *PXI-5 PXI Express Hardware Specification*, Revision 2.0. Contact the PXI Systems Alliance for a copy of the specification.

System Controller Slot Pinouts

Table B-1. XP1 Connector Pinout for the System Controller Slot

Pins	Signals
A	GND
B	12V
C	12V
D	GND
E	5V
F	3.3V
G	GND

Table B-2. XP2 Connector Pinout for the System Controller Slot

Pin	A	B	ab	C	D	cd	E	F	ef
1	3PETp1	3PETn1	GND	3PERp1	3PERn1	GND	3PETp2	3PETn2	GND
2	3PETp3	3PETn3	GND	3PERp3	3PERn3	GND	3PERp2	3PERn2	GND
3	4PETp0	4PETn0	GND	4PERp0	4PERn0	GND	4PETp1	4PETn1	GND
4	4PETp2	4PETn2	GND	4PERp2	4PERn2	GND	4PERp1	4PERn1	GND
5	4PETp3	4PETn3	GND	4PERp3	4PERn3	GND	RSV	RSV	GND
6	RSV	RSV	GND	RSV	RSV	GND	RSV	RSV	GND
7	RSV	RSV	GND	RSV	RSV	GND	RSV	RSV	GND
8	RSV	RSV	GND	RSV	RSV	GND	RSV	RSV	GND
9	RSV	RSV	GND	RSV	RSV	GND	RSV	RSV	GND
10	RSV	RSV	GND	RSV	RSV	GND	RSV	RSV	GND

Table B-3. XP3 Connector Pinout for the System Controller Slot

Pin	A	B	ab	C	D	cd	E	F	ef
1	RSV	RSV	GND	RSV	RSV	GND	RSV	RSV	GND
2	RSV	RSV	GND	PWR_OK	PS_ON#	GND	LINKCAP	PWRBTN#	GND
3	SMBDAT	SMBCLK	GND	4RefClk+	4RefClk-	GND	2RefClk+	2RefClk-	GND
4	RSV	PERST#	GND	3RefClk+	3RefClk-	GND	1RefClk+	1RefClk-	GND
5	1PETp0	1PETn0	GND	1PERp0	1PERn0	GND	1PETp1	1PETn1	GND
6	1PETp2	1PETn2	GND	1PERp2	1PERn2	GND	1PERp1	1PERn1	GND
7	1PETp3	1PETn3	GND	1PERp3	1PERn3	GND	2PETp0	2PETn0	GND
8	2PETp1	2PETn1	GND	2PERp1	2PERn1	GND	2PERp0	2PERn0	GND
9	2PETp2	2PETn2	GND	2PERp2	2PERn2	GND	2PETp3	2PETn3	GND
10	3PETp0	3PETn0	GND	3PERp0	3PERn0	GND	2PERp3	2PERn3	GND

Table B-4. XP4 Connector Pinout for the System Controller Slot

Pin	Z	A	B	C	D	E	F
1	GND	GA4	GA3	GA2	GA1	GA0	GND
2	GND	5Vaux	GND	SYSEN#	WAKE#	ALERT#	GND
3	GND	RSV	RSV	RSV	RSV	RSV	GND
4	GND	RSV	RSV	RSV	RSV	RSV	GND
5	GND	PXI_TRIG3	PXI_TRIG4	PXI_TRIG5	GND	PXI_TRIG6	GND
6	GND	PXI_TRIG2	GND	RSV	PXI_STAR	PXI_CLK10	GND
7	GND	PXI_TRIG1	PXI_TRIG0	RSV	GND	PXI_TRIG7	GND
8	GND	RSV	GND	RSV	RSV	PXI_LBR6	GND

System Timing Slot Pinouts

Table B-5. TP1 Connector Pinout for the System Timing Slot

Pin	A	B	ab	C	D	cd	E	F	ef
1	PXle_DSTARA3+	PXle_DSTARA3-	GND	NC	NC	GND	NC	NC	GND
2	PXle_DSTARC4+	PXle_DSTARC4-	GND	PXI_STAR12	PXI_STAR13	GND	NC	NC	GND
3	PXle_DSTARB4+	PXle_DSTARB4-	GND	NC	NC	GND	NC	NC	GND
4	PXle_DSTARA4+	PXle_DSTARA4-	GND	NC	NC	GND	NC	NC	GND
5	PXle_DSTARC5+	PXle_DSTARC5-	GND	PXI_STAR14	PXI_STAR15	GND	NC	NC	GND
6	PXle_DSTARB5+	PXle_DSTARB5-	GND	NC	NC	GND	NC	NC	GND
7	PXle_DSTARA5+	PXle_DSTARA5-	GND	NC	NC	GND	NC	NC	GND
8	PXle_DSTARC6+	PXle_DSTARC6-	GND	PXI_STAR16	RSV	GND	NC	NC	GND
9	PXle_DSTARB6+	PXle_DSTARB6-	GND	NC	NC	GND	NC	NC	GND
10	PXle_DSTARA6+	PXle_DSTARA6-	GND	NC	NC	GND	NC	NC	GND

Table B-6. TP2 Connector Pinout for the System Timing Slot

Pin	A	B	ab	C	D	cd	E	F	ef
1	NC	NC	GND	PXle_DS TARC8+	PXle_DS TARC8-	GND	PXle_DST ARB8+	PXle_DST ARB8-	GN D
2	NC	NC	GND	NC	NC	GND	PXle_DST ARA8+	PXle_DST ARA8-	GN D
3	NC	NC	GND	PXle_DS TARC1+	PXle_DS TARC1-	GND	NC	NC	GN D
4	PXle_DS TARB1+	PXle_DS TARB1-	GND	PXI_STAR0	PXI_STAR1	GND	NC	NC	GN D
5	PXle_DS TARA1+	PXle_DS TARA1-	GND	PXI_STAR2	PXI_STAR3	GND	NC	NC	GN D
6	PXle_DS TARC2+	PXle_DS TARC2-	GND	PXI_STAR4	PXI_STAR5	GND	NC	NC	GN D

Table B-6. TP2 Connector Pinout for the System Timing Slot (Continued)

Pin	A	B	ab	C	D	cd	E	F	ef
7	PXIe_DS TARB2+	PXIe_DS TARB2-	GND	PXI_ STAR6	PXI_ STAR7	GND	NC	NC	GN D
8	PXIe_DS TARA2+	PXIe_DS TARA2-	GND	PXI_ STAR8	PXI_ STAR9	GND	PXIe_DST ARCI1+	PXIe_DST ARCI1-	GN D
9	PXIe_DS TARC3+	PXIe_DS TARC3-	GND	PXI_ STAR10	PXI_ STAR11	GND	PXIe_DST ARA11+	PXIe_DST ARA11-	GN D
10	PXIe_DS TARB3+	PXIe_DS TARB3-	GND	NC	NC	GND	PXIe_DST ARB11+	PXIe_DST ARB11-	GN D

Table B-7. XP3 Connector Pinout for the System Timing Slot

Pin	A	B	ab	C	D	cd	E	F	ef
1	PXIe_ CLK100+	PXIe_ CLK100-	GND	PXIe_SY NC100+	PXIe_SY NC100-	GND	PXIe_DS TARC+	PXIe_D STARC-	GND
2	PRSENT#	PWREN#	GND	PXIe_DS TARB+	PXIe_DS TARB-	GND	PXIe_DS TARA+	PXIe_D STARA-	GND
3	SMBDAT	SMBCLK	GND	RSV	RSV	GND	RSV	RSV	GND
4	MPWRGD*	PERST#	GND	RSV	RSV	GND	1RefClk+	1RefClk-	GND
5	1PETp0	1PETn0	GND	1PERp0	1PERn0	GND	1PETp1	1PETn1	GND
6	1PETp2	1PETn2	GND	1PERp2	1PERn2	GND	1PERp1	1PERn1	GND
7	1PETp3	1PETn3	GND	1PERp3	1PERn3	GND	1PETp4	1PETn4	GND
8	1PETp5	1PETn5	GND	1PERp5	1PERn5	GND	1PERp4	1PERn4	GND
9	1PETp6	1PETn6	GND	1PERp6	1PERn6	GND	1PETp7	1PETn7	GND
10	RSV	RSV	GND	RSV	RSV	GND	1PERp7	1PERn7	GND

Table B-8. XP4 Connector Pinout for the System Timing Slot

Pin	Z	A	B	C	D	E	F
1	GND	GA4	GA3	GA2	GA1	GA0	GND
2	GND	5Vaux	GND	SYSEN#	WAKE#	ALERT#	GND
3	GND	12V	12V	GND	GND	GND	GND
4	GND	GND	GND	3.3V	3.3V	3.3V	GND
5	GND	PXI_TRIG3	PXI_TRI G4	PXI_TRIG5	GND	PXI_TRIG6	GND
6	GND	PXI_TRIG2	GND	ATNLED	PXI_CLK10_I N	PXI_CLK10	GND

Table B-8. XP4 Connector Pinout for the System Timing Slot (Continued)

Pin	Z	A	B	C	D	E	F
7	GND	PXI_TRIG1	PXI_TRIG0	ATNSW#	GND	PXI_TRIG7	GND
8	GND	PXIe_SYNC_CTRL	GND	RSV	PXI_LBL6	PXI_LBR6	GND

Peripheral Slot Pinouts

Table B-9. P1 Connector Pinout for the Peripheral Slot

Pin	Z	A	B	C	D	E	F
25	GND	5V	REQ64#	ENUM#	3.3V	5V	GND
24	GND	AD[1]	5V	V(I/O)	AD[0]	ACK64#	GND
23	GND	3.3V	AD[4]	AD[3]	5V	AD[2]	GND
22	GND	AD[7]	GND	3.3V	AD[6]	AD[5]	GND
21	GND	3.3V	AD[9]	AD[8]	M66EN	C/BE[0]#	GND
20	GND	AD[12]	GND	V(I/O)	AD[11]	AD[10]	GND
19	GND	3.3V	AD[15]	AD[14]	GND	AD[13]	GND
18	GND	SERR#	GND	3.3V	PAR	C/BE[1]#	GND
17	GND	3.3V	IPMB_SCL	IPMB_SDA	GND	PERR#	GND
16	GND	DEVSEL#	GND	V(I/O)	STOP#	LOCK#	GND
15	GND	3.3V	FRAME#	IRDY#	BD_SEL#	TRDY#	GND
12 to 14	Key Area						
11	GND	AD[18]	AD[17]	AD[16]	GND	C/BE[2]#	GND
10	GND	AD[21]	GND	3.3V	AD[20]	AD[19]	GND
9	GND	C/BE[3]#	IDSEL	AD[23]	GND	AD[22]	GND
8	GND	AD[26]	GND	V(I/O)	AD[25]	AD[24]	GND
7	GND	AD[30]	AD[29]	AD[28]	GND	AD[27]	GND
6	GND	REQ#	GND	3.3V	CLK	AD[31]	GND
5	GND	BRSVP1A5	BRSVP1B5	RST#	GND	GNT#	GND
4	GND	IPMB_PWR	HEALTHY	V(I/O)	INTP	INTS	GND
3	GND	INTA#	INTB#	INTC#	5V	INTD#	GND
2	GND	TCK	5V	TMS	TDO	TDI	GND
1	GND	5V	-12V	TRST#	+12V	5V	GND

Table B-10. P2 Connector Pinout for the Peripheral Slot

Pin	Z	A	B	C	D	E	F
22	GND	GA4	GA3	GA2	GA1	GA0	GND
21	GND	PXI_LBR0	GND	PXI_LBR1	PXI_LBR2	PXI_LBR3	GND
20	GND	PXI_LBR4	PXI_LBR5	PXI_LBL0	GND	PXI_LBL1	GND
19	GND	PXI_LBL2	GND	PXI_LBL3	PXI_LBL4	PXI_LBL5	GND
18	GND	PXI_TRIG3	PXI_TRIG4	PXI_TRIG5	GND	PXI_TRIG6	GND
17	GND	PXI_TRIG2	GND	RSV	PXI_STAR	PXI_CLK10	GND
16	GND	PXI_TRIG1	PXI_TRIG0	RSV	GND	PXI_TRIG7	GND
15	GND	PXI_BRSVA15	GND	RSV	PXI_LBL6	PXI_LBR6	GND
14	GND	RSV	RSV	RSV	GND	RSV	GND
13	GND	RSV	GND	V(I/O)	RSV	RSV	GND
12	GND	RSV	RSV	RSV	GND	RSV	GND
11	GND	RSV	GND	V(I/O)	RSV	RSV	GND
10	GND	RSV	RSV	RSV	GND	RSV	GND
9	GND	RSV	GND	V(I/O)	RSV	RSV	GND
8	GND	RSV	RSV	RSV	GND	RSV	GND
7	GND	RSV	GND	V(I/O)	RSV	RSV	GND
6	GND	RSV	RSV	RSV	GND	RSV	GND
5	GND	RSV	GND	V(I/O)	RSV	RSV	GND
4	GND	V(I/O)	64EN#	RSV	GND	RSV	GND
3	GND	PXI_LBR7	GND	PXI_LBR8	PXI_LBR9	PXI_LBR10	GND
2	GND	PXI_LBR11	PXI_LBR12	UNC	PXI_LBL7	PXI_LBL8	GND
1	GND	PXI_LBL9	GND	PXI_LBL10	PXI_LBL11	PXI_LBL12	GND

Hybrid Slot Pinouts

Table B-11. P1 Connector Pinout for the Hybrid Slot

Pin	Z	A	B	C	D	E	F
25	GND	5V	REQ64#	ENUM#	3.3V	5V	GND
24	GND	AD[1]	5V	V(I/O)	AD[0]	ACK64#	GND
23	GND	3.3V	AD[4]	AD[3]	5V	AD[2]	GND
22	GND	AD[7]	GND	3.3V	AD[6]	AD[5]	GND
21	GND	3.3V	AD[9]	AD[8]	M66EN	C/BE[0]#	GND
20	GND	AD[12]	GND	V(I/O)	AD[11]	AD[10]	GND
19	GND	3.3V	AD[15]	AD[14]	GND	AD[13]	GND
18	GND	SERR#	GND	3.3V	PAR	C/BE[1]#	GND
17	GND	3.3V	IPMB_SCL	IPMB_SDA	GND	PERR#	GND
16	GND	DEVSEL#	GND	V(I/O)	STOP#	LOCK#	GND
15	GND	3.3V	FRAME#	IRDY#	BD_SEL#	TRDY#	GND
12 to 14	Key Area						
11	GND	AD[18]	AD[17]	AD[16]	GND	C/BE[2]#	GND
10	GND	AD[21]	GND	3.3V	AD[20]	AD[19]	GND
9	GND	C/BE[3]#	IDSEL	AD[23]	GND	AD[22]	GND
8	GND	AD[26]	GND	V(I/O)	AD[25]	AD[24]	GND
7	GND	AD[30]	AD[29]	AD[28]	GND	AD[27]	GND
6	GND	REQ#	GND	3.3V	CLK	AD[31]	GND
5	GND	BRSVP1A5	BRSVP1B5	RST#	GND	GNT#	GND
4	GND	IPMB_PWR	HEALTHY#	V(I/O)	INTP	INTS	GND
3	GND	INTA#	INTB#	INTC#	5V	INTD#	GND
2	GND	TCK	5V	TMS	TDO	TDI	GND
1	GND	5V	-12V	TRST#	+12V	5V	GND

Table B-12. XP3 Connector Pinout for the Hybrid Slot

Pin	A	B	ab	C	D	cd	E	F	ef
1	PXIe_CLKI00+	PXIe_CLKI00-	GND	PXIe_SY NC100+	PXIe_SY NC100-	GND	PXIe_DS TARC+	PXIe_DS TARC-	GND
2	PRSNT#	PWREN#	GND	PXIe_DS TARB+	PXIe_DS TARB-	GND	PXIe_DS TARA+	PXIe_DS TARA-	GND
3	SMBDAT	SMBCLK	GND	RSV	RSV	GND	RSV	RSV	GND
4	MPWRGD*	PERST#	GND	RSV	RSV	GND	1RefClk+	1RefClk-	GND
5	1PETp0	1PETn0	GND	1PERp0	1PERn0	GND	1PETp1	1PETn1	GND
6	1PETp2	1PETn2	GND	1PERp2	1PERn2	GND	1PERp1	1PERn1	GND
7	1PETp3	1PETn3	GND	1PERp3	1PERn3	GND	1PETp4	1PETn4	GND
8	1PETp5	1PETn5	GND	1PERp5	1PERn5	GND	1PERp4	1PERn4	GND
9	1PETp6	1PETn6	GND	1PERp6	1PERn6	GND	1PETp7	1PETn7	GND
10	RSV	RSV	GND	RSV	RSV	GND	1PERp7	1PERn7	GND

Table B-13. XP4 Connector Pinout for the Hybrid Slot

Pin	Z	A	B	C	D	E	F
1	GND	GA4	GA3	GA2	GA1	GA0	GND
2	GND	5Vaux	GND	SYSEN#	WAKE#	ALERT#	GND
3	GND	12V	12V	GND	GND	GND	GND
4	GND	GND	GND	3.3V	3.3V	3.3V	GND
5	GND	PXI_TRIG3	PXI_TRIG4	PXI_TRIG5	GND	PXI_TRIG6	GND
6	GND	PXI_TRIG2	GND	ATNLED	PXI_STAR	PXI_CLK10	GND
7	GND	PXI_TRIG1	PXI_TRIG0	ATNSW#	GND	PXI_TRIG7	GND
8	GND	RSV	GND	RSV	PXI_LBL6	PXI_LBR6	GND

NI Services

National Instruments provides global services and support as part of our commitment to your success. Take advantage of product services in addition to training and certification programs that meet your needs during each phase of the application life cycle; from planning and development through deployment and ongoing maintenance.

To get started, register your product at ni.com/myproducts.

As a registered NI product user, you are entitled to the following benefits:

- Access to applicable product services.
- Easier product management with an online account.
- Receive critical part notifications, software updates, and service expirations.

Log in to your National Instruments ni.com User Profile to get personalized access to your services.

Services and Resources

- **Maintenance and Hardware Services**—NI helps you identify your systems' accuracy and reliability requirements and provides warranty, sparing, and calibration services to help you maintain accuracy and minimize downtime over the life of your system. Visit ni.com/services for more information.
 - **Warranty and Repair**—All NI hardware features a one-year standard warranty that is extendable up to five years. NI offers repair services performed in a timely manner by highly trained factory technicians using only original parts at a National Instruments service center.
 - **Calibration**—Through regular calibration, you can quantify and improve the measurement performance of an instrument. NI provides state-of-the-art calibration services. If your product supports calibration, you can obtain the calibration certificate for your product at ni.com/calibration.
- **System Integration**—If you have time constraints, limited in-house technical resources, or other project challenges, National Instruments Alliance Partner members can help. To learn more, call your local NI office or visit ni.com/alliance.

- **Training and Certification**—The NI training and certification program is the most effective way to increase application development proficiency and productivity. Visit ni.com/training for more information.
 - The Skills Guide assists you in identifying the proficiency requirements of your current application and gives you options for obtaining those skills consistent with your time and budget constraints and personal learning preferences. Visit ni.com/skills-guide to see these custom paths.
 - NI offers courses in several languages and formats including instructor-led classes at facilities worldwide, courses on-site at your facility, and online courses to serve your individual needs.
- **Technical Support**—Support at ni.com/support includes the following resources:
 - **Self-Help Technical Resources**—Visit ni.com/support for software drivers and updates, a searchable KnowledgeBase, product manuals, step-by-step troubleshooting wizards, thousands of example programs, tutorials, application notes, instrument drivers, and so on. Registered users also receive access to the NI Discussion Forums at ni.com/forums. NI Applications Engineers make sure every question submitted online receives an answer.
 - **Software Support Service Membership**—The Standard Service Program (SSP) is a renewable one-year subscription included with almost every NI software product, including NI Developer Suite. This program entitles members to direct access to NI Applications Engineers through phone and email for one-to-one technical support, as well as exclusive access to online training modules at ni.com/self-paced-training. NI also offers flexible extended contract options that guarantee your SSP benefits are available without interruption for as long as you need them. Visit ni.com/ssp for more information.
- **Declaration of Conformity (DoC)**—A DoC is our claim of compliance with the Council of the European Communities using the manufacturer’s declaration of conformity. This system affords the user protection for electromagnetic compatibility (EMC) and product safety. You can obtain the DoC for your product by visiting ni.com/certification.

For information about other technical support options in your area, visit ni.com/services, or contact your local office at ni.com/contact.

You also can visit the Worldwide Offices section of ni.com/niglobal to access the branch office websites, which provide up-to-date contact information, support phone numbers, email addresses, and current events.

Glossary

Symbol	Prefix	Value
p	pico	10^{-12}
n	nano	10^{-9}
μ	micro	10^{-6}
m	milli	10^{-3}
k	kilo	10^3
M	mega	10^6
G	giga	10^9
T	tera	10^{12}

Symbols

°	Degrees.
≥	Equal or greater than.
≤	Equal or less than.
%	Percent.

A

A	Amperes.
AC	Alternating current.
ANSI	American National Standards Institute.
Auto	Automatic fan speed control.
AWG	American Wire Gauge.

B

backplane An assembly, typically a printed circuit board, with connectors and signal paths that bus the connector pins.

BNC Bayonet Neill Concelman connector; a commonly used coaxial connector.

C

C Celsius.

cfm Cubic feet per minute.

CFR Code of Federal Regulations.

cm Centimeters.

CompactPCI An adaptation of the Peripheral Component Interconnect (PCI) Specification 2.1 or later for industrial and/or embedded applications requiring a more robust mechanical form factor than desktop PCI. It uses industry standard mechanical components and high-performance connector technologies to provide an optimized system intended for rugged applications. It is electrically compatible with the PCI Specification, which enables low-cost PCI components to be utilized in a mechanical form factor suited for rugged environments.

CSA Canadian Standards Association.

D

daisy-chain A method of propagating signals along a bus, in which the devices are prioritized on the basis of their position on the bus.

DB-9 A 9-pin D-SUB connector.

DC Direct current.

DoC Declaration of Conformity.

D-SUB Subminiature D connector.

E

efficiency	Ratio of output power to input power, expressed as a percentage.
EIA	Electronic Industries Association.
EMC	Electromagnetic Compatibility.
EMI	Electromagnetic Interference.

F

FCC	Federal Communications Commission.
filler panel	A blank module front panel used to fill empty slots in the chassis.

G

g	(1) grams; (2) a measure of acceleration equal to 9.8 m/s ² .
GPIB	General Purpose Interface Bus (IEEE 488).
g_{RMS}	A measure of random vibration. The root mean square of acceleration levels in a random vibration test profile.

H

hr	Hours.
Hz	Hertz—cycles per second.

I

IEC	International Electrotechnical Commission—an organization that sets international electrical and electronics standards.
IEEE	Institute of Electrical and Electronics Engineers.
I_{MP}	Mainframe peak current.

Glossary

in. Inches.

inhibit To turn off.

J

jitter A measure of the small, rapid variations in clock transition times from their nominal regular intervals. Units: seconds RMS.

K

kg Kilograms.

km Kilometers.

L

lb Pounds.

LED Light emitting diode.

line regulation The maximum steady-state percentage that a DC voltage output will change as a result of a specified change in input AC voltage (step change from 90 to 132 VAC or 180 to 264 VAC).

load regulation The maximum steady-state percentage that a DC voltage output will change as a result of a step change from no-load to full-load output current.

M

m Meters.

MHz Megahertz—One million Hertz; one Hertz equals one cycle per second.

mi Miles.

ms Milliseconds.

MTBF	Mean time between failure.
MTTR	Mean time to repair.
N	
NEMA	National Electrical Manufacturers Association.
NI	National Instruments.
P	
power supply shuttle	A removable module that contains the chassis power supply.
PXI	PCI eXtensions for Instrumentation.
PXI_CLK10	10 MHz PXI system reference clock.
R	
RH	Relative humidity.
RMS	Root mean square.
S	
s	Seconds.
skew	Deviation in signal transmission times.
slot blocker	An assembly installed into an empty slot to improve the airflow in adjacent slots.
standby	The backplane is unpowered (off), but the chassis is still connected to AC power mains.
System controller	A module configured for installation in Slot 1 of a PXI chassis. This device is unique in the PXI system in that it performs the system controller functions, including clock sourcing and arbitration for data transfers across the backplane. Installing such a device into any other slot can damage the device, the PXI backplane, or both.

Glossary

system reference clock

A 10 MHz clock, also called PXI_CLK10, that is distributed to all peripheral slots in the chassis, as well as a BNC connector on the rear of chassis labeled *10 MHz REF OUT*. The system reference clock can be used for synchronization of multiple modules in a measurement or control system. The 10 MHz REF IN and OUT BNC connectors on the rear of the chassis can be used to synchronize multiple chassis to one reference clock. The PXI backplane specification defines implementation guidelines for PXI_CLK10.

System Timing slot

This slot is located at slot 4 and has dedicated trigger lines to other slots.

T

TTL

Transistor-transistor logic.

U

UL

Underwriter's Laboratories.

V

V

Volts.

VAC

Volts alternating current.

V_{pp}

Peak-to-peak voltage.

W

W

Watts.

Index

B

backplane

- hybrid peripheral slots, 1-6
- interoperability with CompactPCI, 1-5
- overview, 1-5
- PXI Express peripheral slots, 1-6
- PXI local bus, routing, 1-8
- PXI peripheral slots, 1-6
- PXIe_SYNC_CTRL, 1-12
- specifications, A-6
- system controller slot, 1-5
- system reference clock, 1-9
 - default behavior (figure), 1-10
 - routing (figure), 1-10
- system timing slot, 1-6
- trigger bus, 1-9

C

- CE compliance specifications, A-5
- chassis ambient temperature definitions, 2-4
- chassis configuration Web page (figure), 2-11
- chassis cooling considerations
 - ambient temperature definitions, 2-4
 - clearances, 2-2
 - figure, 2-3
 - vents (figure), 2-4
- chassis description, 1-3
- chassis fan LED behavior (table), 2-14
- chassis initialization file, 2-18
- chassis LED indicators, 2-12
- chassis ventilation (figure), 2-4
- cleaning chassis, 3-1
- clearances for chassis cooling, 2-2
 - figure, 2-3
- CLK10 rear connectors, 2-15
- CompactPCI, interoperability with PXIe-1066DC backplane, 1-5
- configuration in MAX (figure), 2-16
- configuration. *See* installation, configuration, and operation

cooling

- air cooling of PXIe-1066DC chassis, 2-2
- filler panel installation, 2-5
- setting fan speed, 2-5
- slot blocker installation, 2-5

D

- DC input connector (figure), 2-7
- default configuration settings, 2-12
- dimensions (figure), A-9, A-10
- documentation, related, *ix*

E

- electromagnetic compatibility, A-5
- EMC filler panel kit, 1-4
- Ethernet LED behavior (figure), 2-12
- external clock source specifications, A-7

F

- fan access door clearance (figure), 2-5
- fan assembly (figure), 3-7
- fan, setting speed, 2-5
- filler panel installation, 2-5

H

- hybrid peripheral slots, description, 1-6
- hybrid slot pinouts
 - P1 connector (table), B-8
 - XP3 connector (table), B-9
 - XP4 connector (table), B-9

I

- IEC 320 inlet, 1-4, 3-3, 3-4, 3-7
- inhibit mode switch, 2-15
- installation, configuration, and operation
 - chassis initialization file, 2-18
 - configuration in MAX (figure), 2-16
 - filler panel installation, 2-5
 - installing a PXI Express system controller, 2-8
 - figure, 2-8

- module installation
 - CompactPCI or PXI modules (figure), 2-10
- peripheral module installation, 2-9
 - figure, 2-10
- PXI Express configuration in MAX, 2-15
- PXI Express system controller installed in a PXIe-1066DC chassis (figure), 2-9
- PXI trigger bus routing, 2-17
- PXI-1 configuration in MAX, 2-16
- rack mounting, 2-6
- setting fan speed, 2-5
- site considerations, 2-2
- slot blocker installation, 2-5
- testing power up, 2-6
- trigger configuration in MAX, 2-17
- unpacking the PXIe-1066DC, 1-1
- installing a PXI Express system controller (figure), 2-8
- interoperability with CompactPCI, 1-5

K

- key features, 1-2
- kit contents, 1-1

L

- local bus, routing (figure), 1-8

M

- main chassis LED behavior (table), 2-13
- maintenance of PXIe-1066DC chassis, 3-1
 - cleaning, 3-1
 - exterior cleaning, 3-2
 - interior cleaning, 3-1
 - fan assembly, replacing, 3-6
 - power supply, replacing, 3-2
 - preparation, 3-1
 - service interval, 3-1
 - static discharge damage (caution), 3-1

O

- optional equipment, 1-4

P

- peripheral module installation, 2-9
 - figure, 2-10
- peripheral slot pinouts
 - P1 connector (table), B-6
 - P2 connector (table), B-7
- pinouts, B-1
- power drawer (figure), 3-4
- power source, connecting to, 2-6
- power supply
 - connecting to, 2-6
 - LED behavior (table), 2-14
 - removing (figure), 3-3
 - replacing, 3-2
- power up, testing, 2-6
- power-on test, 2-7
- PXI differential star trigger specifications (PXIe-DSTARA, PXIe-DSTARB, PXIe-DSTARC), A-8
- PXI Express configuration in MAX, 2-15
- PXI Express peripheral slots, description, 1-6
- PXI Express system controller, 2-8
 - figure, 2-8
 - installing in a PXIe-1066DC chassis (figure), 2-9
- PXI local bus, routing, 1-8
- PXI peripheral slots, description, 1-6
- PXI star trigger specifications, A-8
- PXI star, routing, 1-7
- PXI-1 configuration in MAX, 2-16
- PXIe_DSTAR, routing (figure), 1-7
- PXIe_SYNC_CTRL, 1-12
 - specifications, A-7
 - using as restart (figure), 1-12
- PXIe-1066DC
 - fan assembly, replacing, 3-6
 - fan speed, setting, 2-5
 - front view (figure), 1-3
 - installation. *See* installation, configuration, and operation
 - key features, 1-2
 - maintenance. *See* maintenance of PXIe-1066DC chassis
 - optional equipment, 1-4
 - power drawer (figure), 3-4

- power supply, replacing, 3-2
- rack mounting, 2-6
- rear view (figure), 1-4
- removing power supply (figure), 3-3
- unpacking, 1-1
- with fan assembly removed (figure), 3-7
- PXIe-1066DC backplane
 - backplane external clock input truth table, 1-11
 - hybrid peripheral slots, 1-6
 - interoperability with CompactPCI, 1-5
 - overview, 1-5
 - PXI Express peripheral slots, 1-6
 - PXI local bus, routing, 1-8
 - PXI peripheral slots, 1-6
 - PXIe_SYNC_CTRL, 1-12
 - using as restart (figure), 1-12
 - specifications, A-6
 - system controller slot, 1-5
 - system reference clock, 1-9
 - default behavior (figure), 1-10
 - routing (figure), 1-10
 - system timing slot, 1-6
 - trigger bus, 1-9
- R**
 - rack mount kit dimensions (figure), A-11
 - rack mounting, 2-6
 - kit, 1-4
 - related documentation, *ix*
 - remote inhibit and fault connector pinout (table), 2-14
 - remote inhibit and fault monitoring, 2-14
 - remote system monitoring, 2-11
- S**
 - safety and caution notices, 2-1
 - safety ground, connecting to, 2-6
 - safety specifications, A-4
 - service interval, 3-1
 - setting fan speed, 2-5
 - slot blocker
 - installation, 2-5
 - kit, 1-4
 - specifications, A-1
 - acoustic emissions
 - sound power, A-4
 - sound pressure level (at operator position), A-4
 - backplane, A-6
 - 10 MHz system reference clock (PXI_CLK10), A-6
 - 100 MHz Reference Out BNC, A-7
 - 100 MHz system reference clock (PXIe_CLK100 and PXIe_SYNC100), A-7
 - CE compliance, A-5
 - chassis cooling, A-3
 - dimensions (figure), A-9, A-10
 - electrical, DC output, A-1
 - electromagnetic compatibility, A-5
 - environmental
 - operating environment, A-3
 - storage environment, A-4
 - external clock source, A-7
 - mechanical, A-8
 - online product certification, A-5
 - PXI differential star triggers (PXIe-DSTARA, PXIe-DSTARB, PXIe-DSTARC), A-8
 - PXI star trigger, A-8
 - PXIe_SYNC_CTRL, A-7
 - rack mount kit dimensions (figure), A-11
 - safety, A-4
 - shock and vibration, A-4
 - system reference clocks, A-6
 - static discharge damage (caution), 3-1
 - system configuration file, 2-18
 - system controller slot
 - description, 1-5
 - pinouts
 - XP1 connector (table), B-2
 - XP2 connector (table), B-2
 - XP3 connector (table), B-3
 - XP4 connector (table), B-3
 - system reference clock, 1-9
 - default behavior (figure), 1-10
 - routing (figure), 1-10
 - specifications, A-6

Index

system timing slot

- description, 1-6

- pinouts

 - TP1 connector (table), B-4

 - TP2 connector (table), B-4

 - XP3 connector (table), B-5

 - XP4 connector (table), B-5

T

- trigger bus, 1-9

U

- unpacking the PXIe-1066DC chassis, 1-1